

Muurkas 1929 op borstwering

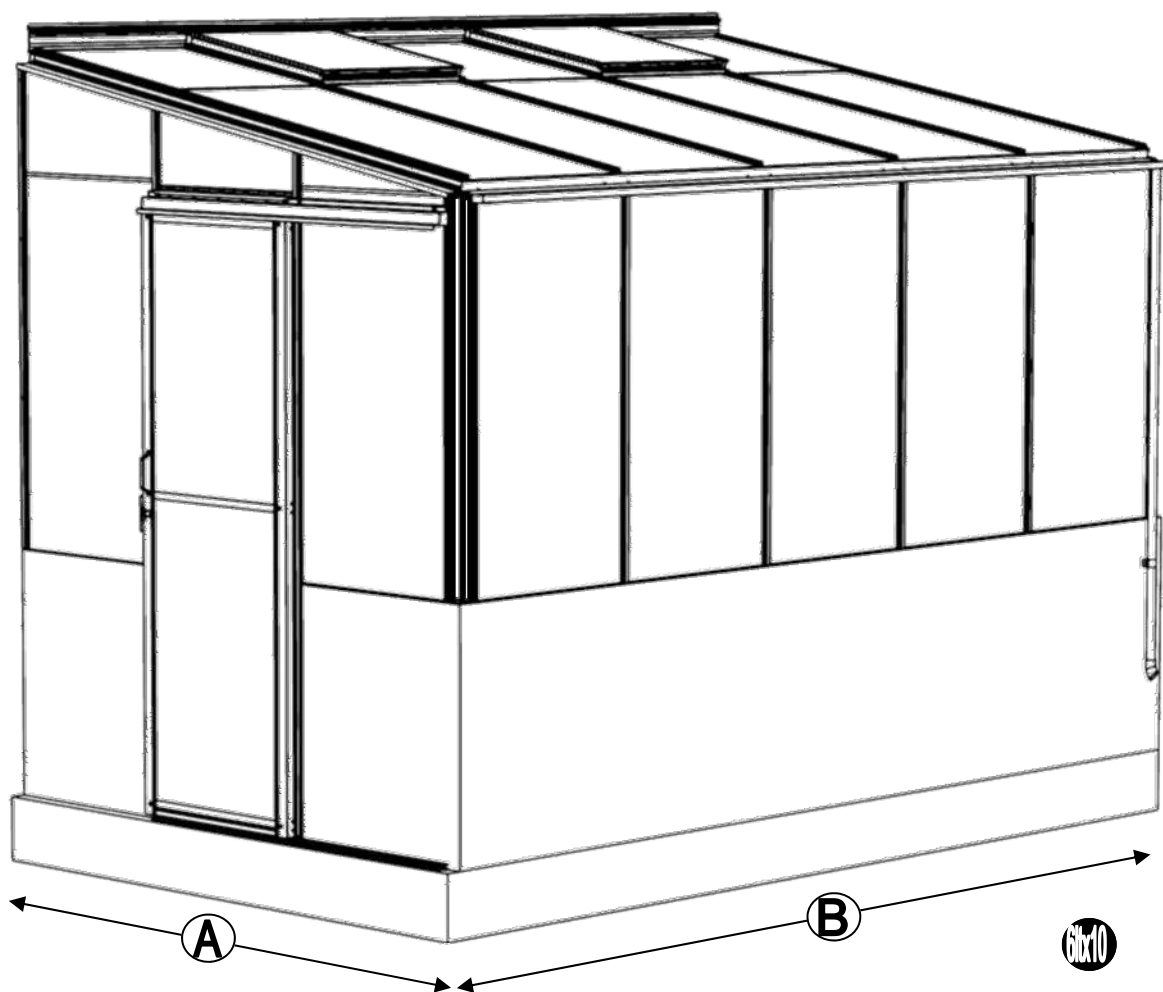

NOMINAL SIZE	A (mm)	B (mm)
6lt x 6	1929	1990
6lt x 8		2610
6lt x 10		3230
6lt x 12		3850

NOMINAL SIZE	A (mm)	B (mm)
6ft extension	-	1860

Bedankt voor de aankoop van uw nieuwe Robinsons tuinkas. Wij raden u aan de instructies te lezen en alle veiligheidsinformatie door te nemen voordat u begint met de montage.

Deze handleiding is onderverdeeld in secties die gemarkeerd worden door een wit nummer/letter op een zwarte achtergrond in de rechterhoek van de meeste pagina's (zie de volgende pagina voor meer informatie); onderdelenlijst, **B**-base/fundering, **V**-voorbereiding, **1**-zijwanden, **2**-voorwand, **3**-achterwand, **4**-de wanden aan elkaar bevestigen, **5**-dak, **6**-achterwandbevestiging, **7**-dakraam, **8**-deur, **9**-beglazing, **10**-dakraambevestiging, **11**-deurbevestiging, **12**-verankering, **13**-optionele lamellenramen, **14**-optionele opbergplanken, **15**-optionele werktafel, **16**-afwerking. Indien u contact met ons moet opnemen voor hulp, verwijst dan naar de betreffende sectie(s). Als uw tuinkas langer is dan 3872 mm, dan komt er een extensie aan uw kas. Raadpleeg dan ook de aparte uitbreidingshandleiding.

Veiligheidswaarschuwing

- Glas en aluminium kan letsel veroorzaken. Zorg ervoor dat u een **veiligheidsbril, handschoenen, veiligheidshelm** en **geschikt schoeisel** draagt tijdens het monteren en beglazen van de tuinkas.
- Denk eraan dat glas breekbaar is en dat u er voorzichtig mee om moet gaan. Ruim gebroken glas altijd onmiddellijk op en gooi het weg.
- Zet de kas niet in elkaar bij harde wind; verifieer de weersvoorspelling voor de periode waarop de tuinkas wordt gemonteerd.
- Om veiligheidsredenen en om de montage te vergemakkelijken, raden we u aan om de kas door minimaal twee personen te laten monteren.
- Verwijder altijd de sneeuw dat op het dak van de kas ligt om overbelasting van de kas te voorkomen.
- Bij harde wind of storm is het gevaarlijk om in de kas aanwezig te zijn.
- Uw kas is geleverd met gehard glas. De zijde waar u doorheen kijkt is extreem sterk, maar de randen zijn erg gevoelig. Zet daarom nooit het glas op de grond zonder klosjes eronder.

Vorbereiding van de werkplek

- Een betonnen of betegelde fundering biedt de meest solide basis voor uw tuinkas.
- **BELANGRIJK:** Zet uw de kas pas vast aan de grond als deze volledig gemonteerd is, inclusief beglazing.
- Plaats uw kas niet onder bomen of op andere kwetsbare locaties.
- Probeer een beschutte locatie te kiezen, bijvoorbeeld naast een haag of tuinhek, om het risico op windschade te minimaliseren.

Aanvullende opmerkingen

- Houd er rekening mee dat de montage van uw kas tijdrovend werk is. Het is verstandig om de montage over twee of meer dagen te verspreiden. We raden u aan om de tuinkas niet gedeeltelijk beglaasd achter te laten om windschade te voorkomen.
- Het is handig om een grote, schone en overzichtelijke werkplek voor te bereiden. Een garagevloer of vlak grasveld is ideaal.
- Het verankeren van uw kas is de laatste fase (na het beglazen).
- Eenmaal geïnstalleerd heeft uw kas weinig onderhoud nodig, maar om ervoor te zorgen dat uw deur(en) soepel blijven lopen, kunt u WD40 aanbrengen op de deurwielen en de deurgeleiders.

Garantie

- Uw nieuwe Robinsons kas heeft 10 jaar garantie tegen fabrieksfouten aan het frame. Dit omvat geen glas, bewegende onderdelen en schade door ongevallen of windschade.

Robinsons afdekljsten:

Bij een Robinsons tuinkas bestaan de afdekljsten uit twee delen. De onderste zwarte kunststof afdekljsten worden op het frame geschroefd. Hierdoor wordt het glas op het rubber profiel gedrukt. Daarna moeten de bovenste aluminium afdekljsten worden aangebracht. Op deze manier worden de kopjes van de RVS schroeven afgedekt. Indien u moeite heeft met het aandrukken van de afdekljsten, raden wij u aan om een rubberen hamer of een houten blok en hamer te gebruiken. Een korte, scherpe tik op de afdekljst aan één kant is alles wat nodig is om deze vast te zetten.

Sommige aluminium afdekljsten hebben aan één kant een gat dat wordt gebruikt om de onderdelen aan op te hangen tijdens het poedercoaten. Als u wilt, kunt u het gat gebruiken om te voorkomen dat de afdekljsten in het dak schuiven.







DRAAG EEN VEILIGHEIDSBRIL EN HANDSCHOENEN OM LETSEL TE VOORKOMEN!











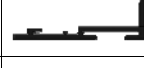

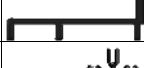
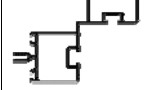
ICOON	BETEKENIS
	BUITENAANZICHT
	BINNENAANZICHT
	DENK
	DEZE SECTIE HEEFT BETREKKING OP EEN ANDERE (bijvoorbeeld 1 en 5)
	CORRECT
	<u>NIET</u> VASTZETTEN!
	DRAAIEN OM TE VERGRENDELEN
	AANDRAAIEN
	DRUKKEN EN VASTHOUDEN
	KNIP OP LENGTE



SECTIE NUMMER	TITEL	MONTAGE SAMENVATTING: BELANGRIJKE INFORMATIE / OVERWEGINGEN
	ONDERDELEN- LIJST	Monteer eerst alle wanden separaat op een vlakke schone ondergrond. Sorteert de onderdelen en leg ze in de vorm zoals op de tekening is aangegeven. Pak niet alle bundels tegelijk uit. Zorg dat u georganiseerd te werk gaat. Onderdelen kunnen worden geïdentificeerd aan de hand van hun profielfoto's en opgegeven lengtes.
B	BASE/ FUNDERING	Afmetingen en aanbevelingen voor de fundering. Zorg ervoor dat uw fundering vlak en waterpas is. Iedere oneffenheid komt terug in het gebouw bij het beglazen!
V	VOORBEREIDING	Benodigde gereedschappen o.a.: 2x steeksleutel 10mm, stanley-mes, kitspuit, kruiskopschroevendraaier, schroefmachine (niet voor bouten/moeren!), waterpas, veiligheidsbril, veiligheidshelm en handschoenen.
1	ZIJWAND(EN)	Neem het tuinkasprofiel met de rubbers erin en de diagonale schoren, gebruik 10mm bouten om ze aan de goot te bevestigen en gebruik 15mm bouten aan de dorpels (let op hoe de kop van de bouten in elk profiel schuift tijdens de constructie).
2	VOORWAND	Zorg er opnieuw voor dat het frame is gerubberd en volg de instructies om het frame van de kas in elkaar te zetten. Zorg ervoor dat u de extra bouten heeft aangebracht die u in sectie 4, 5 en 11 heeft moeten gebruiken. Voor de dak- en zijhoekbalken is niet voor elke sleuf rubber nodig, tenzij u een (optionele) scheidingswand heeft (zie aparte handleiding en sectie V).
3	ACHTERWAND	
4	DE WANDEN AAN ELKAAR BEVESTIGEN	Neem de zijwand(en) (1), de voorwand (2) en de achterwand (3) en voeg ze samen op de fundering.
5	DAK	Bevestig de nok en plaats vervolgens de gerubberde dakprofielen. Zorg ervoor dat de deze volledig tegen de nok en de goot aanliggen. Er worden buisvormige beugels meegeleverd voor extra stevigheid. Deze kunnen nu of later worden gemonteerd met (hamerkop)bouten.
6	ACHTERWAND BEVESTIGING	Zorg ervoor dat u de kas volledig horizontaal en haaks tegen de muur bevestigd door een waterpas op de nok en tegen de zijwanden te houden.
7a	DAKRAAM	Gebruik silicone om de glasplaat in de sponning vast te zetten. Ook zonder silicone blijft het dakraam in het profielwerk zitten. Soms komen de gaatjes niet 100% overeen bij het monteren van het dakraam. U kunt deze dan eenvoudig opboren met een 7mm boortje zodat de onderdelen alsnog in elkaar passen.
7b	RAAMDORPEL	Plaats de raamdorpel nadat u de glasplaat heeft geplaatst die eronder komt. Op die manier heeft u direct de juiste plek. De raamdorpel schuift iets over het glas heen.
8	DEUR	Monteer de deur op aan de hand van de instructies. Leg de deur aan de kant klaar voor bevestiging in sectie (11).
9	BEGLAZING	Voor u het glas plaatst kunt u de zwarte schroeflijsten alvast rondom de kas klaarleggen. In sommige gevallen moeten de zwarte lijsten nog iets worden ingekort. Ook is het belangrijk dat de gaatjes waar de RVS schroeven doorheen gaan ook op het uiteinde zitten. Neem een 6.5mm boortje om eventueel nog een gaatje bij te boren. Leg eerst de glasplaat linksachter op het dak, dan linksachter in de zijwand en in de kopgevel linksachter. Op deze manier kunt u zien of het frame helemaal recht en haaks staat. Meestal moet er nog een en ander afgesteld worden voor u het glas in de kas kunt monteren. Na linksachter kunt u rechtsvoor erin zetten. Hierdoor weet u (zeker bij grotere kassen) dat al het glas er netjes in komt te liggen. Helemaal perfect bestaat bijna niet. In de ondergrond zit altijd wel een kleine oneffenheid.
10	DAKRAAM- BEVESTIGING	Neem het voorgemonteerde dakraam en schuif deze aan de voor- of achterzijde in de nok. Vergeet niet om onderdeel D220 voor en achter het raam te plaatsen zodat het raam op zijn plek blijft.
11	DEUR- BEVESTIGING	Gebruik de boutjes die u al heeft ingevoerd bij stap 2 om de deurgeleider te bevestigen. De onderdorpel moet in elkaar worden geklikt. Zorg dat de ondergrond 100% recht en vlak is.
12	VERANKERING	Nu de kas volledig is gemonteerd en het glas in de sponningen is geplaatst kunt u de kas verankeren aan de ondergrond.
13	OPTIONELE LAMELLENRAMEN	De lamellenramen plaatst u tijdens het beglazen met een zwart H-profiel eronder en erboven.
14	OPTIONELE OPBERG- PLANKEN	Robinsons opbergplanken en werktafels zijn een efficiënte en integrale oplossing. Let op dat het monteren tijdrovend is. U kunt bij het voorbereiden van de kas boutjes en moertjes in de profielen schuiven zodat u het gebruik van hamerkopbouten voorkomt. Met de vierkante boutjes is het monteren een stuk gemakkelijker. Neem rustig de tijd om de tafel en plank te installeren.
15	OPTIONELE WERKTAFEL	
16	AFWERKING	Als laatste kunt u de regenpijpen monteren. Kit e.e.a. goed af om lekkage te voorkomen.

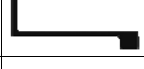



Section Ref	Part No.	Section	Size (mm)	6lt 6	6lt 8	6lt 10	6lt 12
-------------	----------	---------	-----------	-------	-------	--------	--------







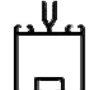

1	D043		1894	1			
	D021		2514		1		
	D022		3134			1	
	D023		3754				1
	D975		1897	1			
	D974		2517		1		
	D979		3137			1	
	D978		3757				1
	D604		1316	2			
	D609		1160	2	3	4	5
	RUBBER		1000 (1m)	5	7	10	12
	D174		N/A	2	2	4	4

2 3	D036		1890			1	
	D628		650			1	
	D605(R)		690			1	
	D606(L)		690			1	
	D632L		650			1	
	D632R		650			1	
	D608		1160			2	
	D955		2037			1	
	D956		2147			1	
	D985		1487			2	
	D992		1267			1	
	D993		1377			1	
	D962		1890			1	
	D950L		1915			1	
	D950R					1	









Section Ref	Part No.	Section	Size (mm)	6lt 6	6lt 8	6lt 10	6lt 12
-------------	----------	---------	-----------	-------	-------	--------	--------

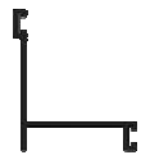

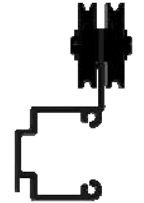
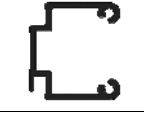
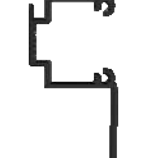
2 3	RUBBER		1000 (1m)		29		
	D174		N/A		8		

5	D976		1897	1			
	D973		2517		1		
	D981		3137			1	
	D977		3757				1
	D593		1897	1			
	D594		2517		1		
	D595		3137			1	
	D596		3757				1
	D951		1915	2	3	4	5
	RUBBER		1000 (1m)	8	12	16	20

7	D866		639	1	1	2	2
	D863L		613	1	1	2	2
	D863R		613	1	1	2	2
	D862		593	1	1	2	2
	D079 PLUS FLUFF		590	1	1	2	2
	D114		N/A	2	2	4	4
	D220 PLUS FS6060 SCREW		N/A	2	2	4	4
	D205		N/A	2	2	4	4

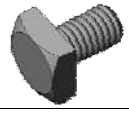
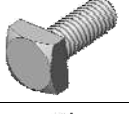

Section Ref	Part No.	Section	Size (mm)	6lt 6	6lt 8	6lt 10	6lt 12
-------------	----------	---------	-----------	-------	-------	--------	--------









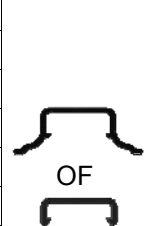



8	D090 + D347 lock = D301		1824		1		
	D094		1824		1		
	D096 + D217 wheel = D307		611		1		
	D095		611		1		
	D097		611		1		
	D232		905		2		
	D233		797		2		
	P053		N/A		1		
	D225		610		1		
	D840B		4000		1		

HOOFDFRAME HOEVEELHEDEN DAKRAMEN/DEUREN ECT. APART		10mm	16	19	22	25	
			15mm	31	32	33	34
				m6	47	51	55

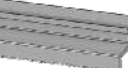

Section Ref	Part No.	Section	Size (mm)	6lt 6	6lt 8	6lt 10	6lt 12
-------------	----------	---------	-----------	-------	-------	--------	--------

9	5	D541		1915	2	3	4	5
	1	D618		1144	2	3	4	5
	2	D969		140	1			
	2	D971		250	1			
	3	D987		1370	1			
	3	D991	1260	1				
	5	D547		1915	2			
	2/3	D610		1160	2			
	1	D620		1144	2			
	2	D814		1883	2			
2/3	D986	1480		2				
5	D544		1915	4	5	6	7	
2/3	D614		1162	2				
1	D619		1144	4	5	6	7	
2	D836		1883	2				
2	D970		140	1				
2	D972		250	1				
3	D988		1370	1				
2/3	D989		1480	2				
3	D990		1260	1				

11	D864		590	1			
	D860		1240	1			
	D087		587	1			
	D084		1270	1			
	D083		1270	1			
	D153		198	1			
	D163		90	2			
	D154		N/A	1			
	D222/B		590	1			
	D112		650	1			
	D845		N/A	2			
	D842		N/A	1			

RICHTLIJNEN VOOR ROBINSONS MUURKASSEN FUNDERING

Onder een opgemetselde muur dient u ten alle tijden een fundering aan te brengen. Afhankelijk van de ondergrond zijn hiervoor verschillende mogelijkheden. Raadpleeg een lokale specialist indien u hierover meer informatie nodig heeft.

De verschillende bodemsamenstellingen in Nederland vergen verschillende manieren van aanpak. Klei, veen, zand en de diepte van de bovenlaag verschillen overal.

Indien u een halfsteens muur metselt of laat metselen zorg dan dat op de hoeken bij de deur de muur steens wordt terug gemetseld. Er ontstaat dan een kolom waardoor de muur extra stevig is op deze punten.



Aan de voorzijde van de kas komt buiten de muur een deurgelijder van 50mm breed op de bodem. Daarom moet er aan de voorzijde ondersteuning zijn (bijvoorbeeld een betonnenrand) die op dezelfde hoogte ligt als de deur.



Property of 'Robinsons Greenhouses' © 2015

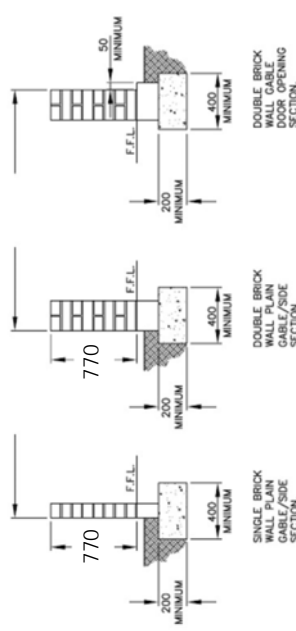

50mm MINIMUM

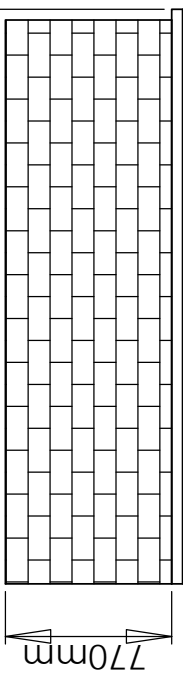

TOTALE LENGTE 'L'

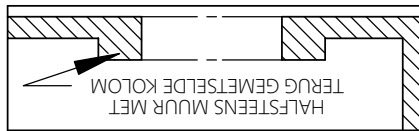
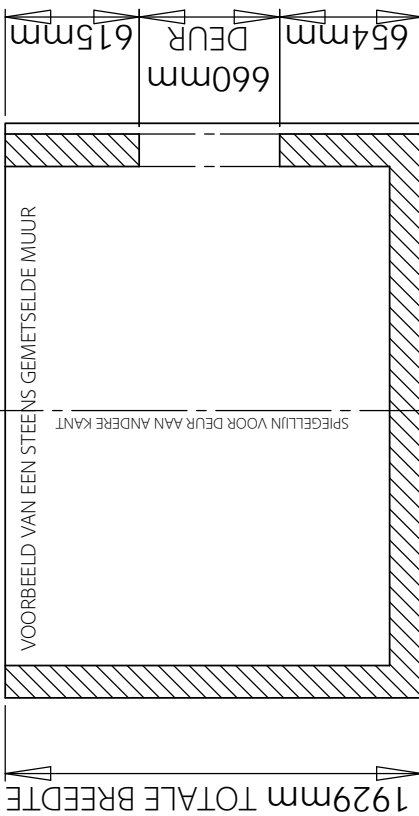

TOTALE LENGTE 'L' = BASISLENGTE VAN DE KAS + EXTENSIE INDIEN NODIG

BASIS TUINKAS	LENGTE	EXTENSIE TUINKAS	LENGTE
6ft LONG	1990mm	6ft EXT LONG	1860mm
8ft LONG	2610mm	8ft EXT LONG	2480mm
10ft LONG	3230mm	10ft EXT LONG	3100mm
12ft LONG	3850mm	12ft EXT LONG	3720mm



Breng rubberprofiel aan in elk glasprofiel en snijd af op lengte. Let op dat sommige kanalen van het glasprofiel niet gebruikt worden. Dit gaat om de voorwand, achterwand en de hoeken. Zie de voorbeelden hiernaast.

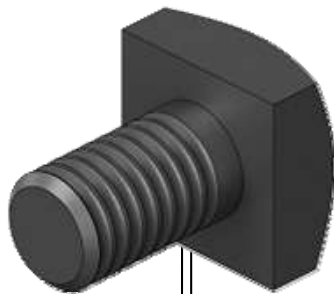
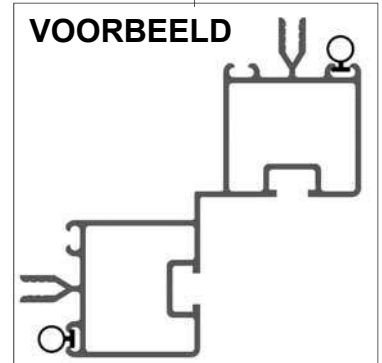
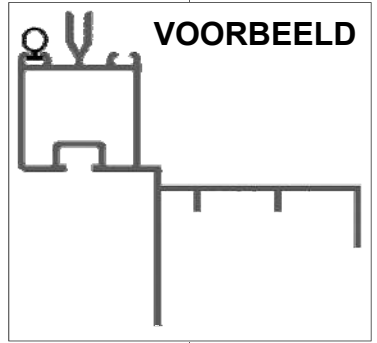
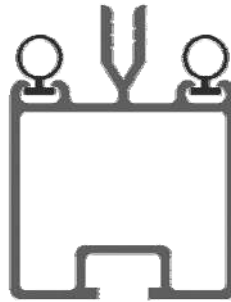

Het frame wordt in elkaar gezet door bouten met een vierkante kop van 10 of 15 mm lengte. Plaats deze in de sleuven van de glasprofielen. Vervolgens moeten de bouten door gaten in gordingen, dorpels ect. worden geplaatst. Tegen het einde van de bouw worden ook (rechthoekige) hamerkopbouten gebruikt om onderdelen aan het frame te bevestigen. Deze bouten kunnen achteraf nog gemonteerd worden in tegenstelling tot de vierkante standaard bouten.

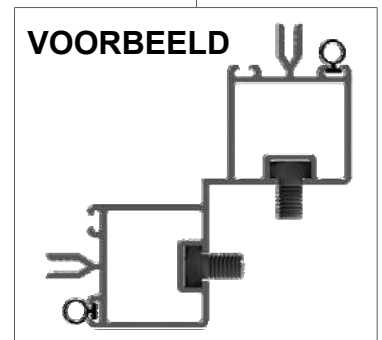
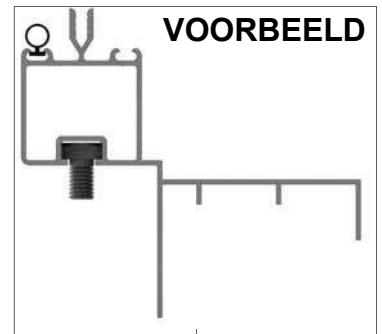
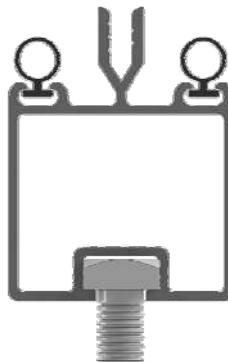
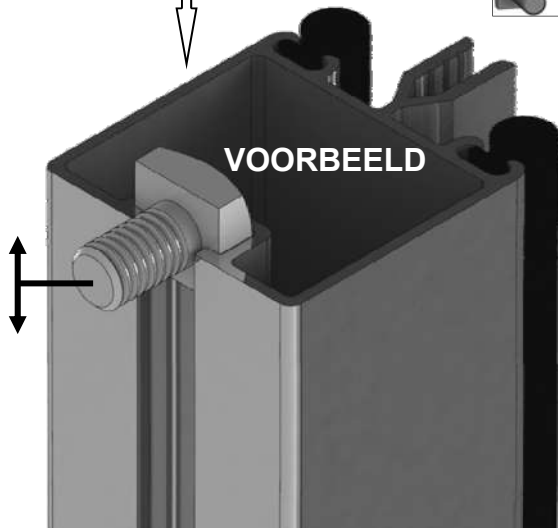

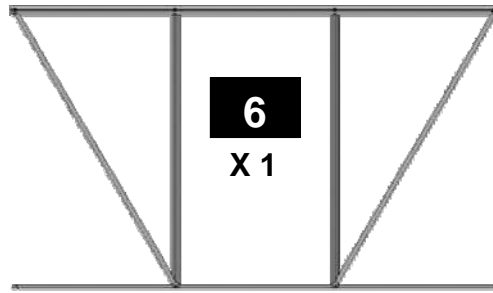
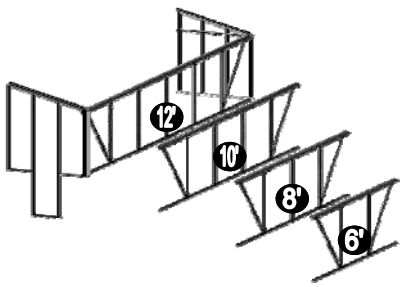

6
X 1

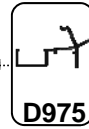

6 X 1 DWARF		
Part No	mm	Quantity
D975	1897	1
D043	1894	1
D609	1160	2
D604	1316	2
D174		2
M6-10mm		2
M6-15mm		4
M6-NUT		6
Rubber	1000	5

VOORBEELD ①

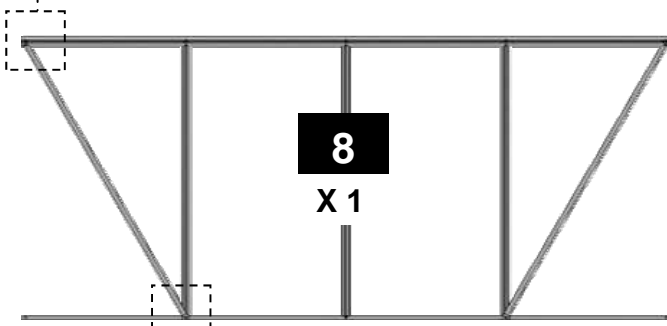

8
X 1

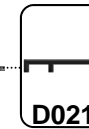
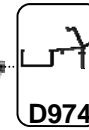

8 X 1 DWARF		
Part No	mm	Quantity
D974	2517	1
D021	2514	1
D609	1160	3
D604	1316	2
D174		2
M6-10mm		3
M6-15mm		5
M6-NUT		8
Rubber	1000	7

VOORBEELD ②

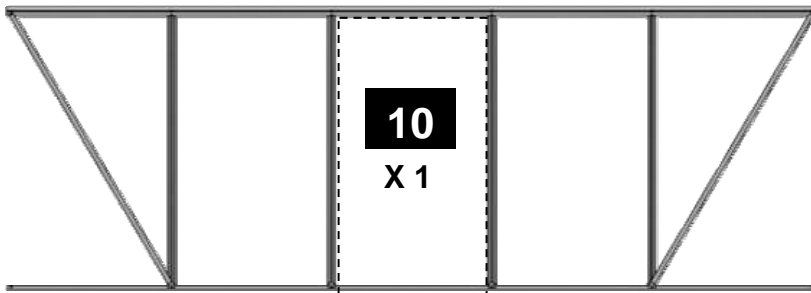

10
X 1

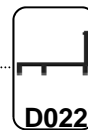
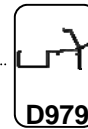

10 X 1 DWARF		
Part No	mm	Quantity
D979	3137	1
D022	3134	1
D609	1160	4
D604	1316	2
D174		4
M6-10mm		4
M6-15mm		6
M6-NUT		10
Rubber	1000	10

SPECIALY ORDERED
OPTIONAL SINGLE / DOUBLE
DOOR ON SIDE?



VOORBEELD

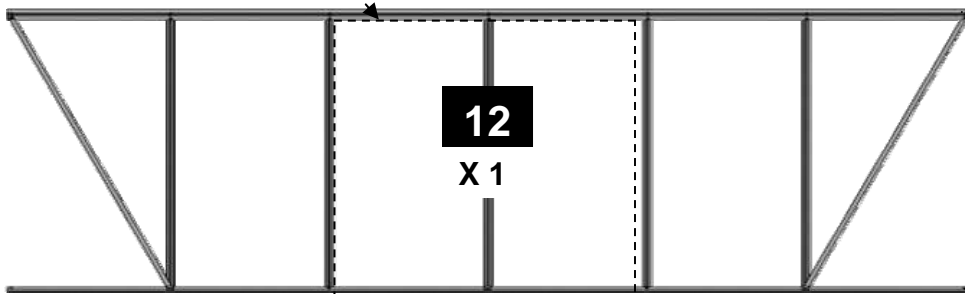

12
X 1

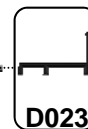
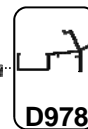

12 X 1 DWARF		
Part No	mm	Quantity
D978	3757	1
D023	3754	1
D609	1160	5
D604	1316	2
D174		4
M6-10mm		5
M6-15mm		7
M6-NUT		12
Rubber	1000	12

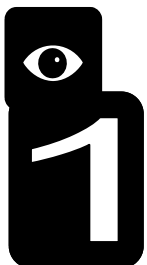

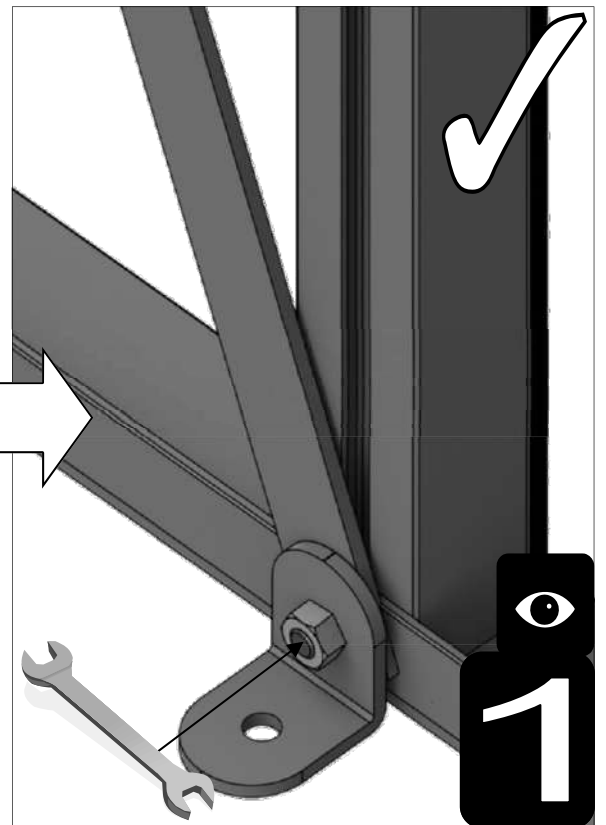
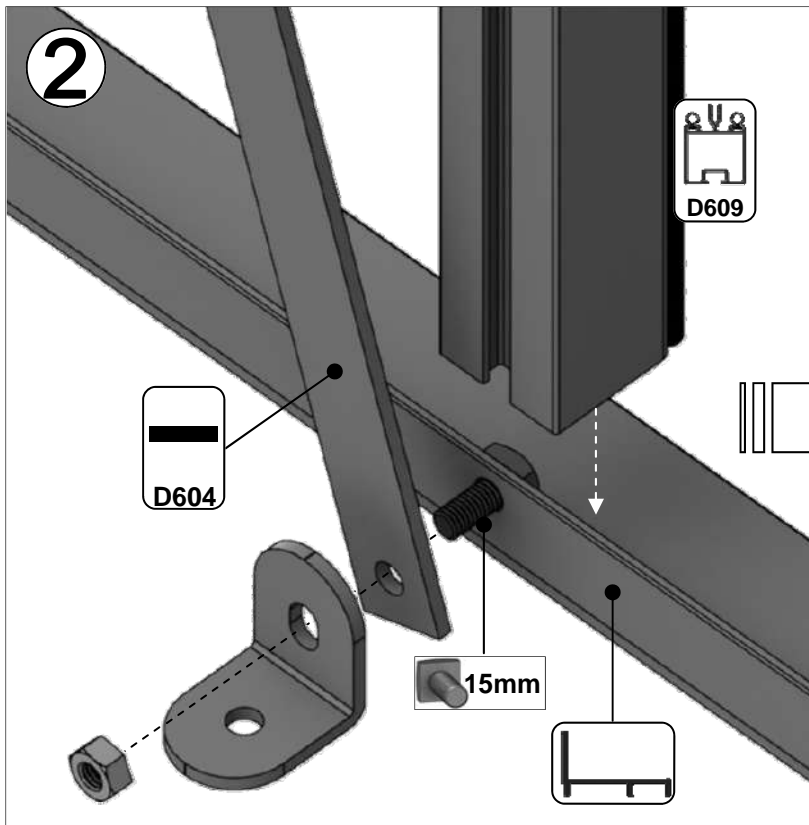
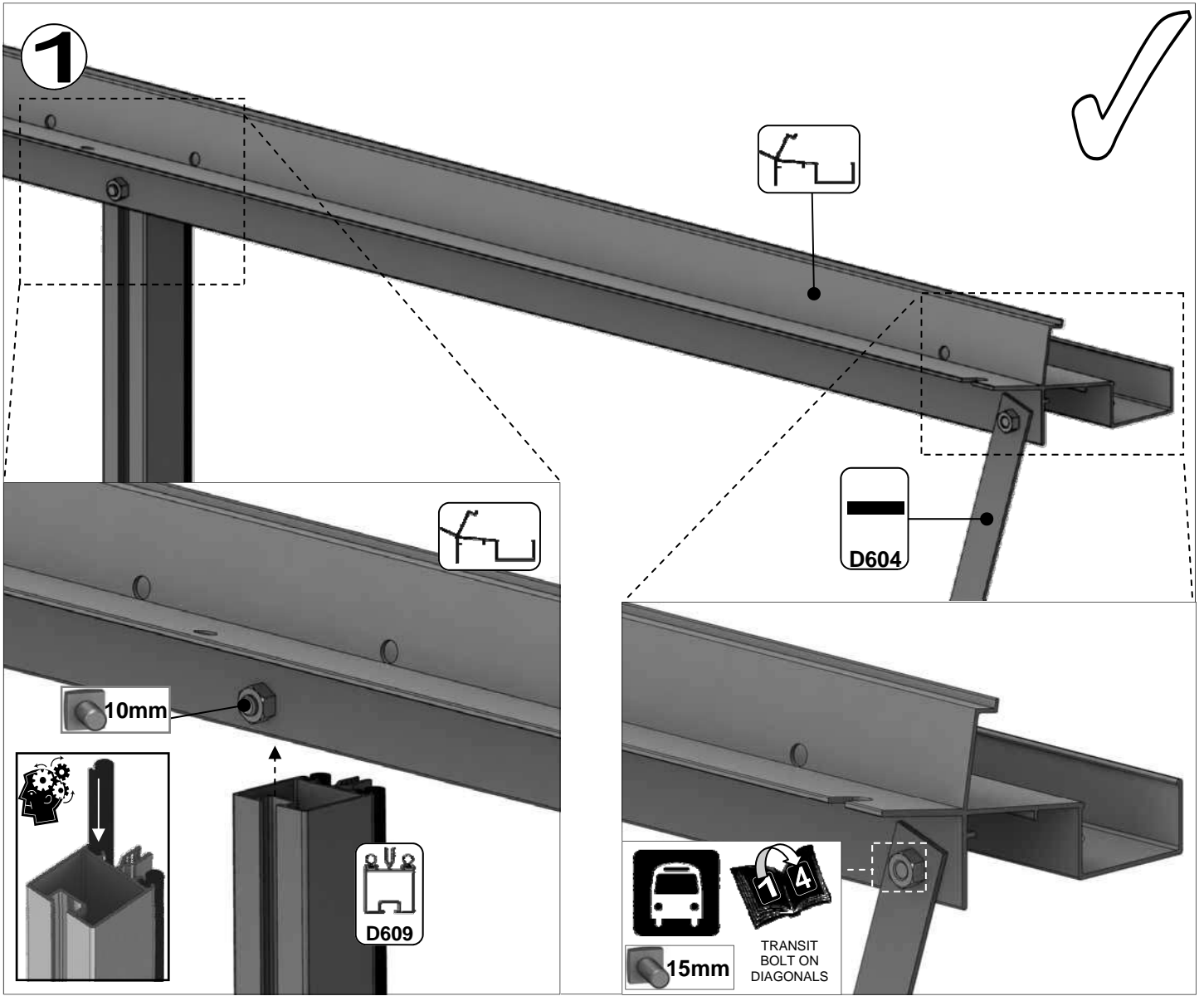

Part No	mm	Quantity
D605(R)	690	1
D608	1160	1
D628	650	1
D632L	650	1
D950R	1915	1
D955	2037	1
D956	2147	1
D985	1487	1

DEUR LINKS
BUITEN-
AANZICHT

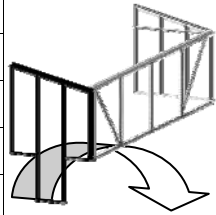

Part No	mm	Quantity
D174		4
D227		16
M6X10		8
M6X15		10
M6NUT		18

DEUR RECHTS
BUITEN-
AANZICHT

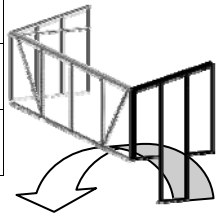

Part No	mm	Quantity
D606(L)	690	1
D608	1160	1
D628	650	1
D632R	650	1
D950L	1915	1
D955	2037	1
D956	2147	1
D985	1487	1

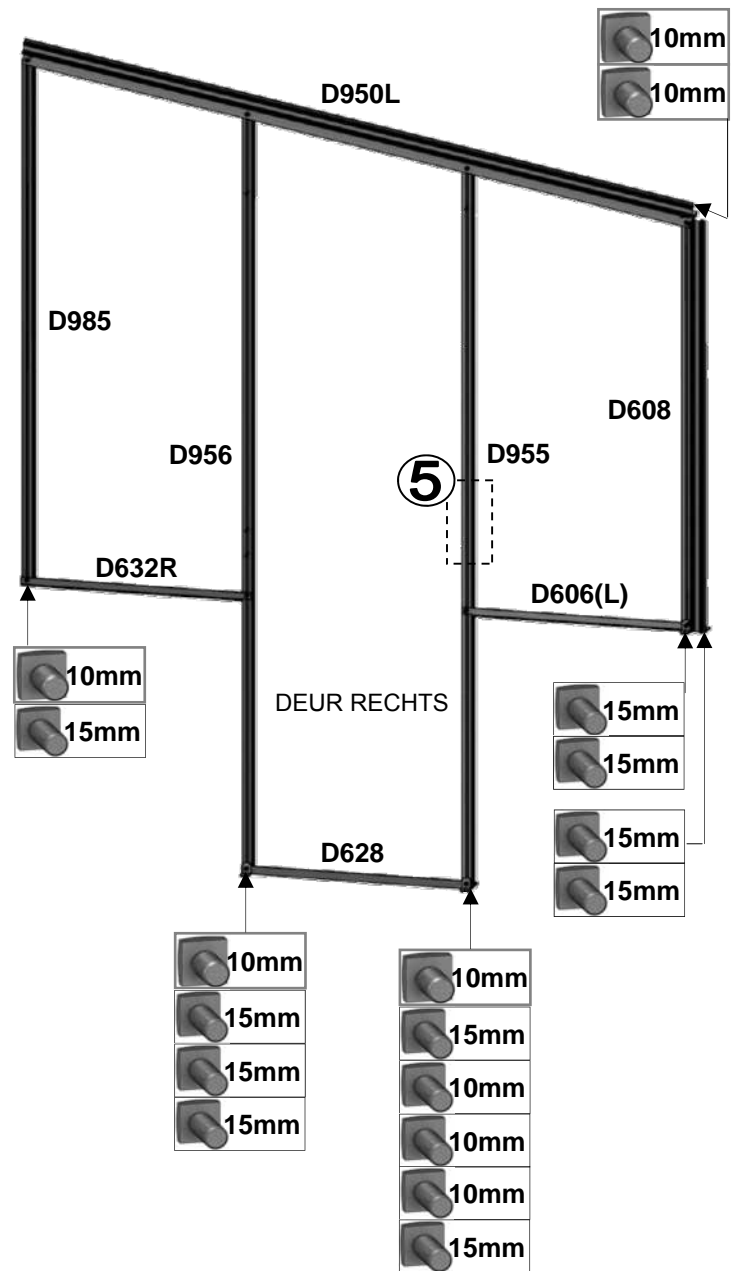
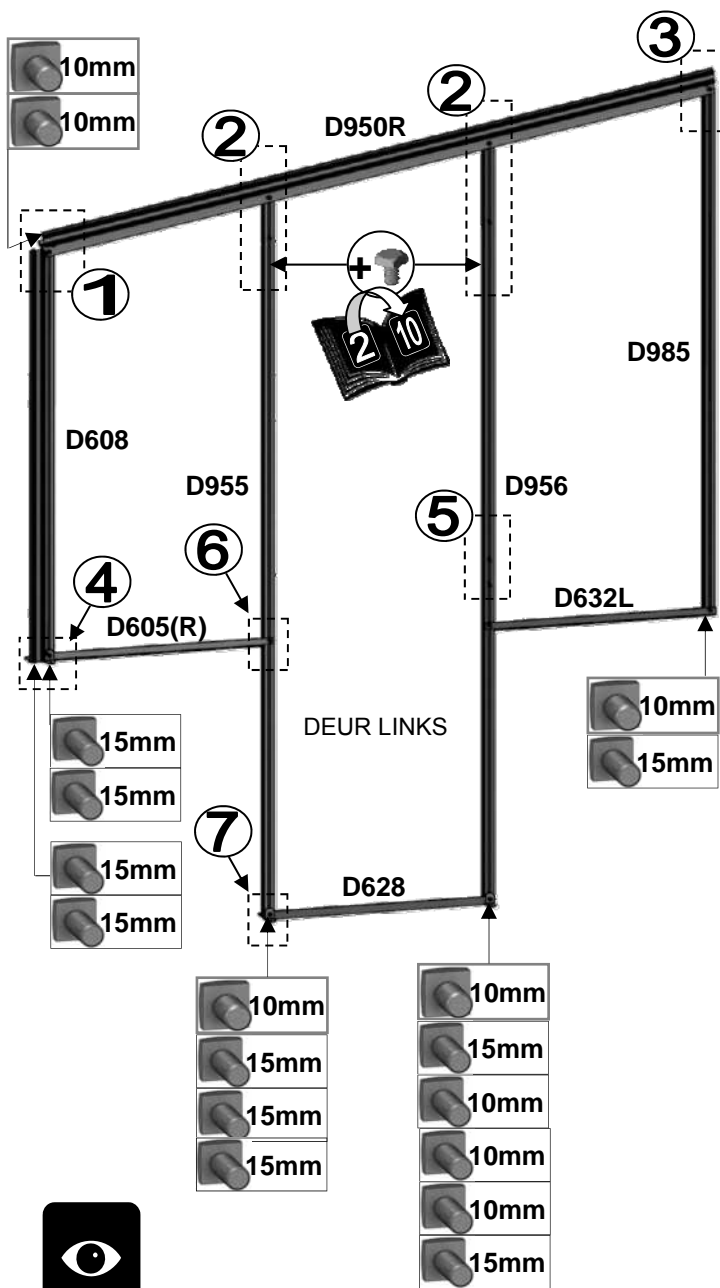

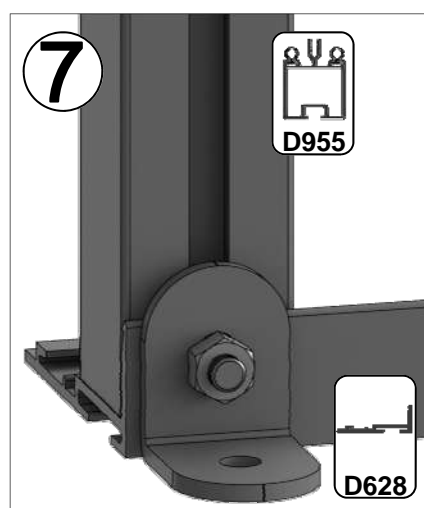
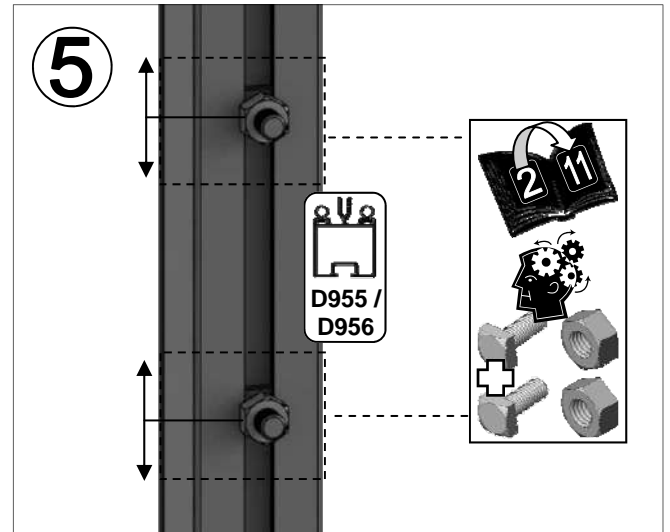
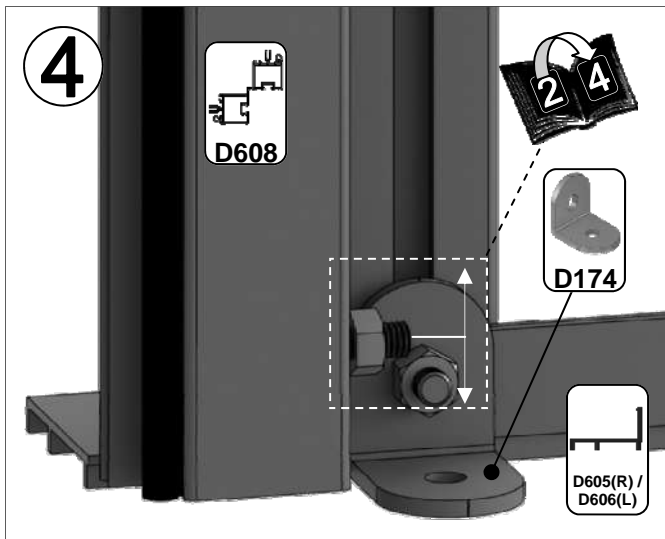
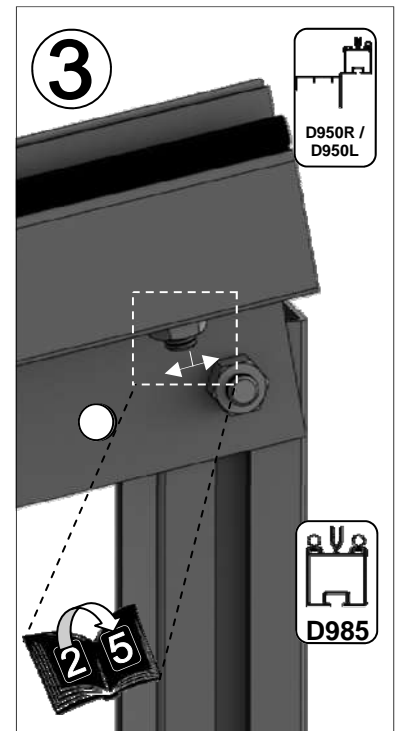
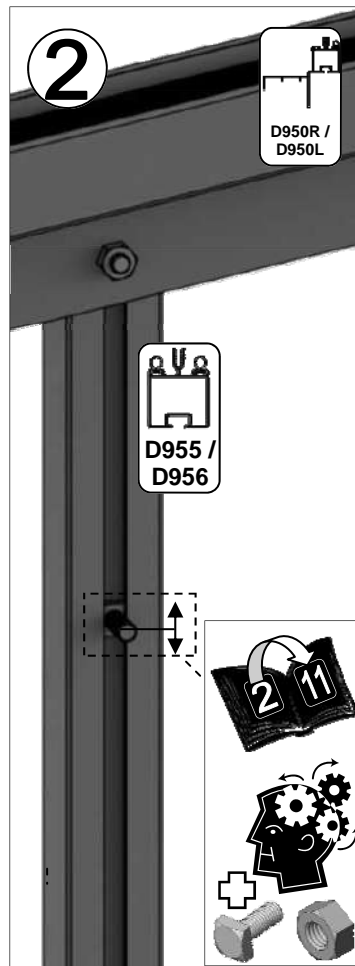
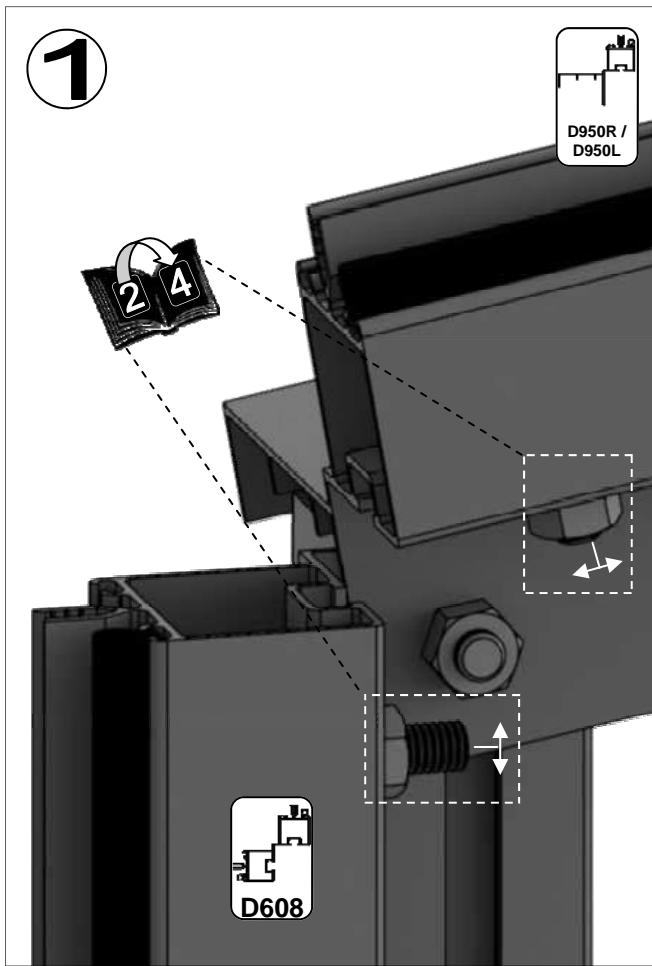

Part No	mm	Quantity
D036	1890	1
D608	1160	1
D950L	1915	1
D962	1890	1
D985	1487	1
D992	1267	1
D993	1377	1

DEUR LINKS
BUITEN-
AANZICHT

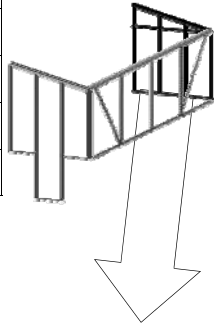

Part No	mm	Quantity
D174		4
D227		11
M6X10		5
M6X15		10
M6NUT		15

DEUR RECHTS
BUITEN-
AANZICHT

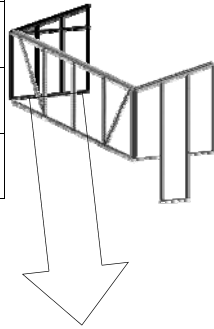

Part No	mm	Quantity
D036	1890	1
D608	1160	1
D950R	1915	1
D962	1890	1
D985	1487	1
D992	1267	1
D993	1377	1

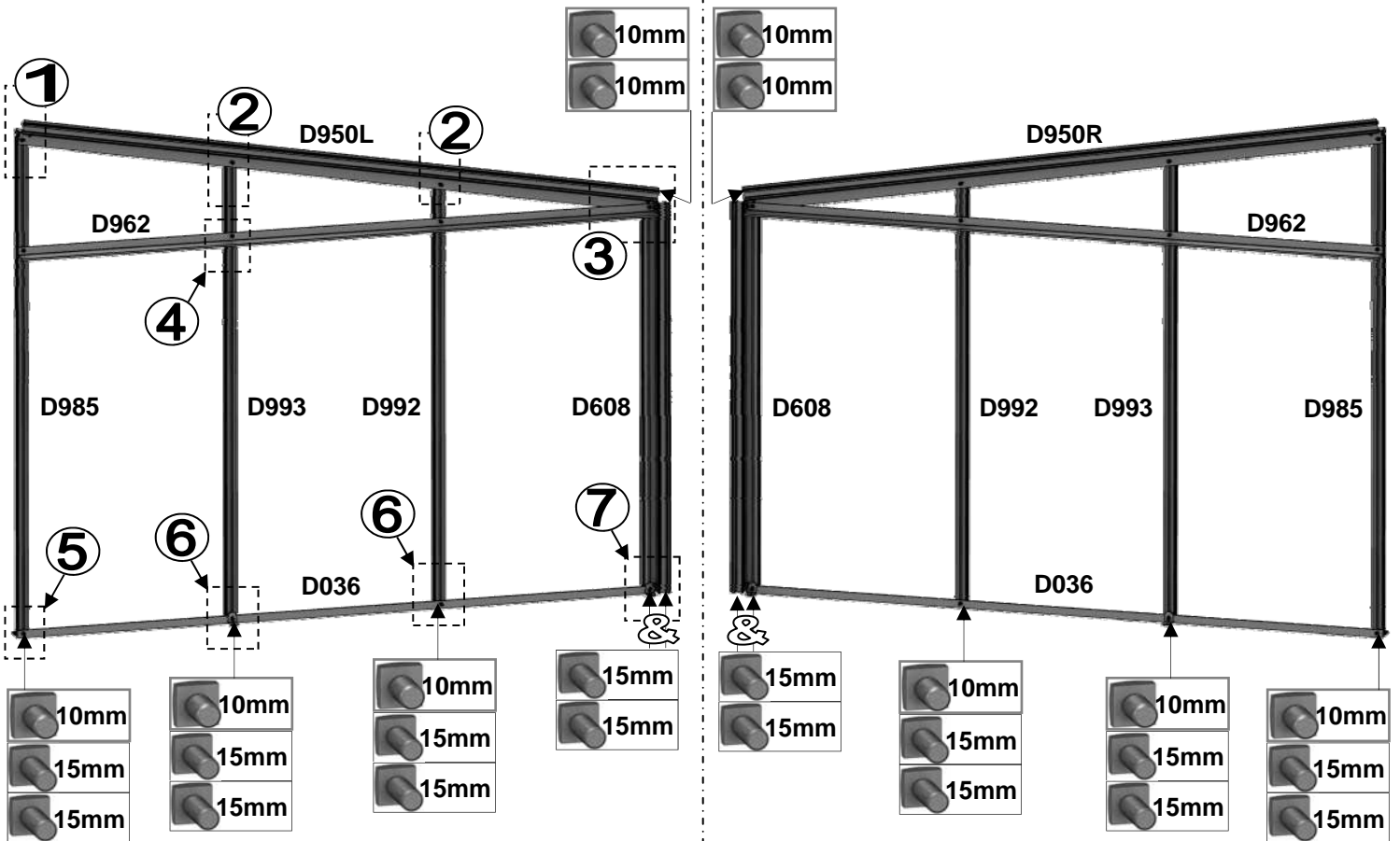

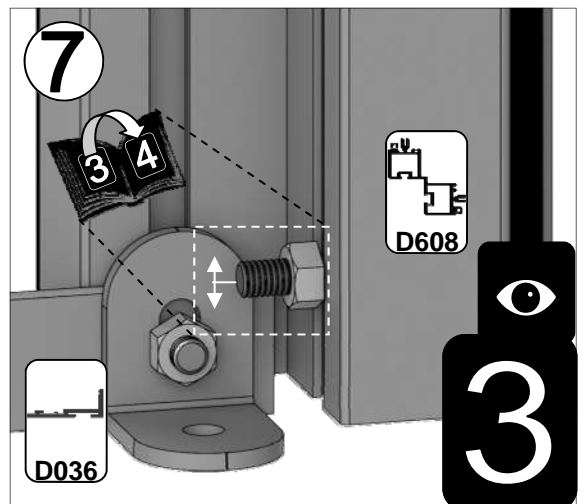
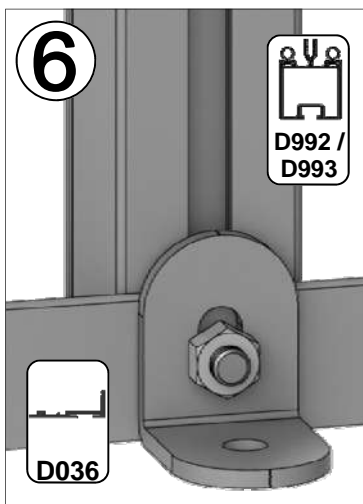
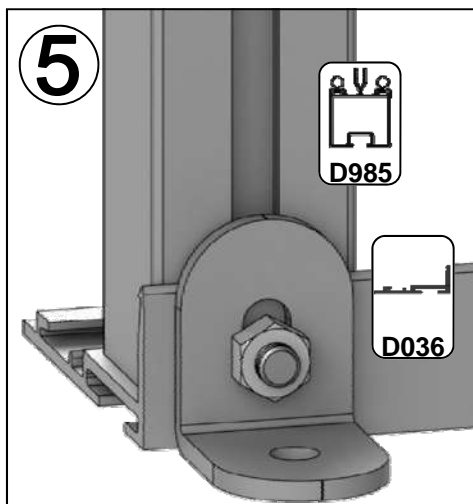
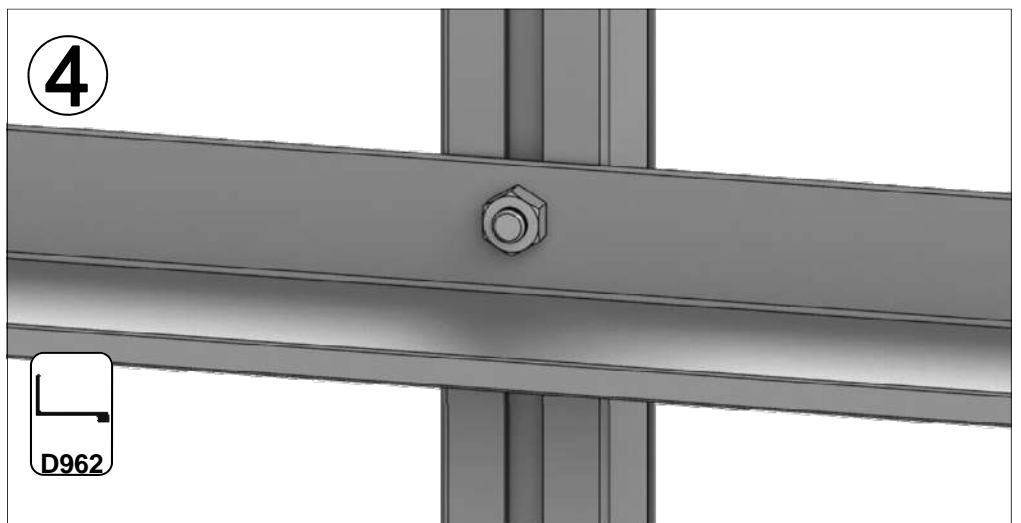
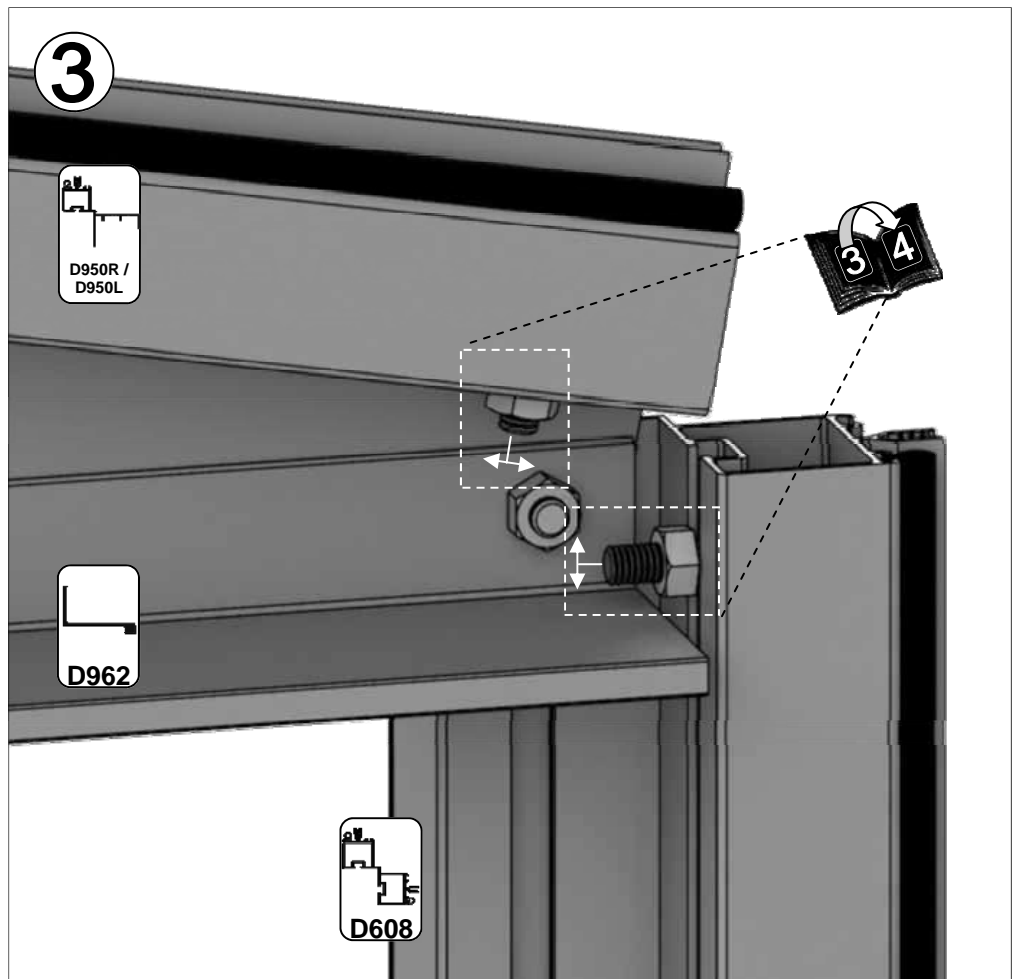
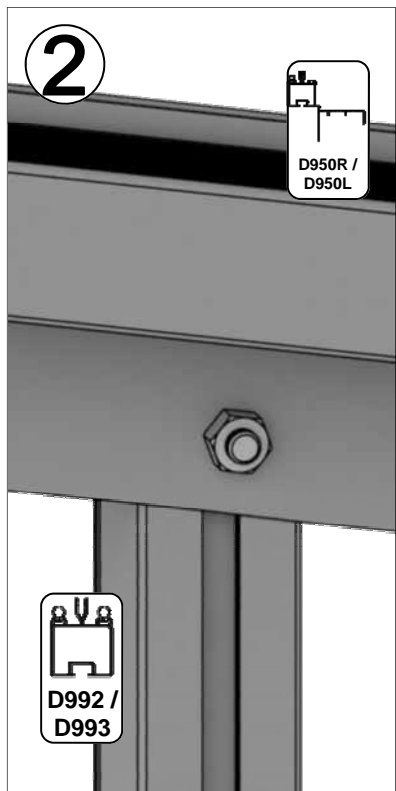
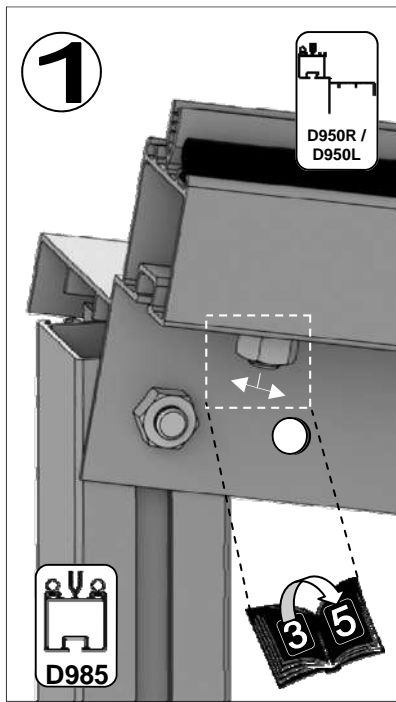

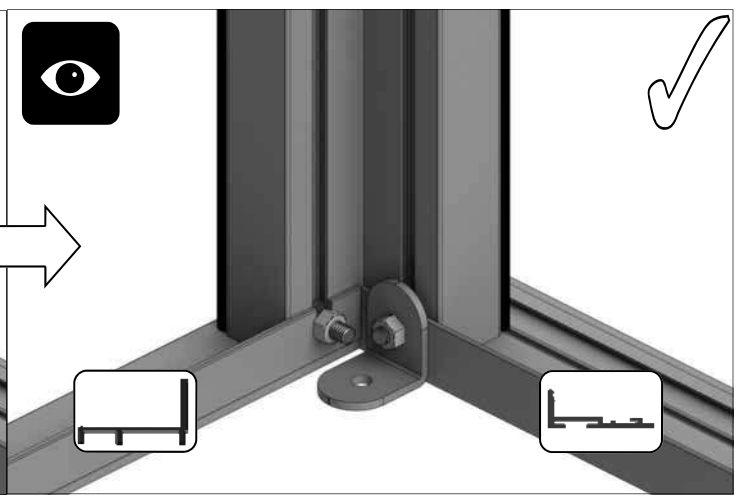
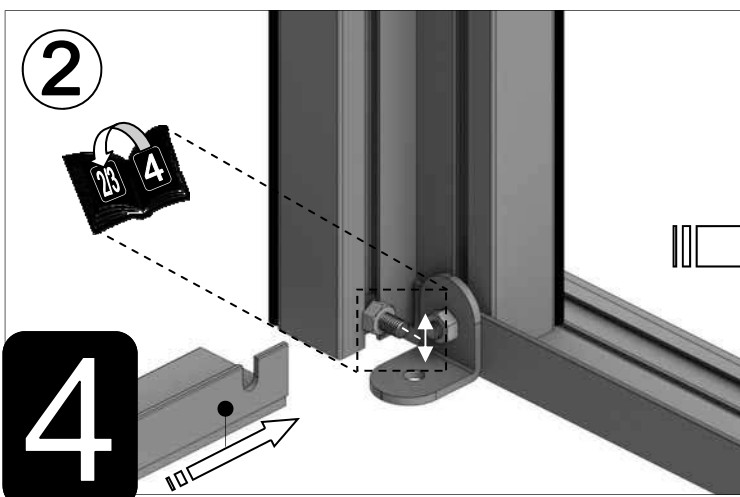
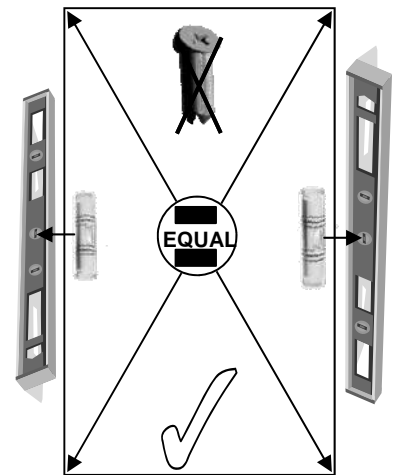
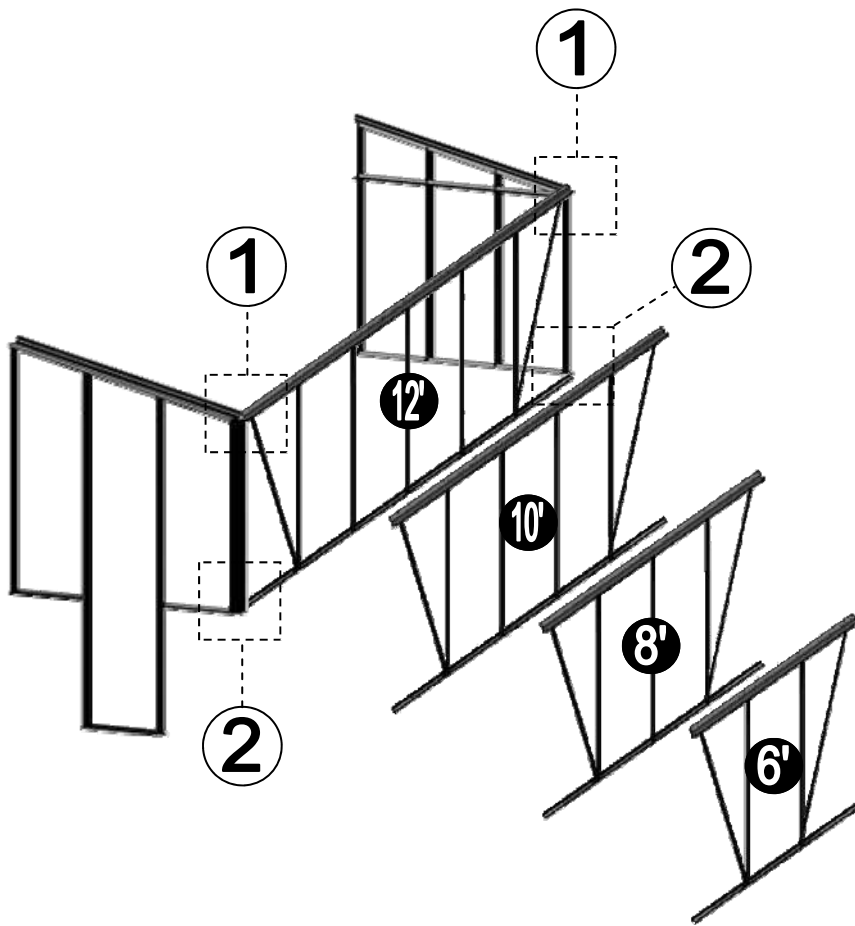
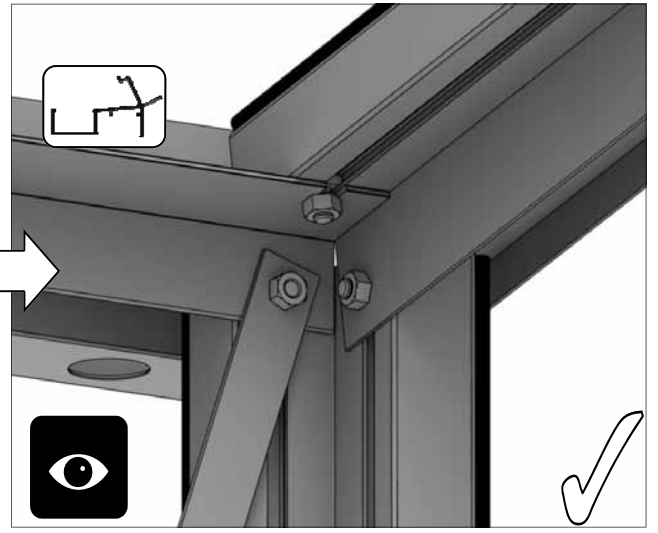
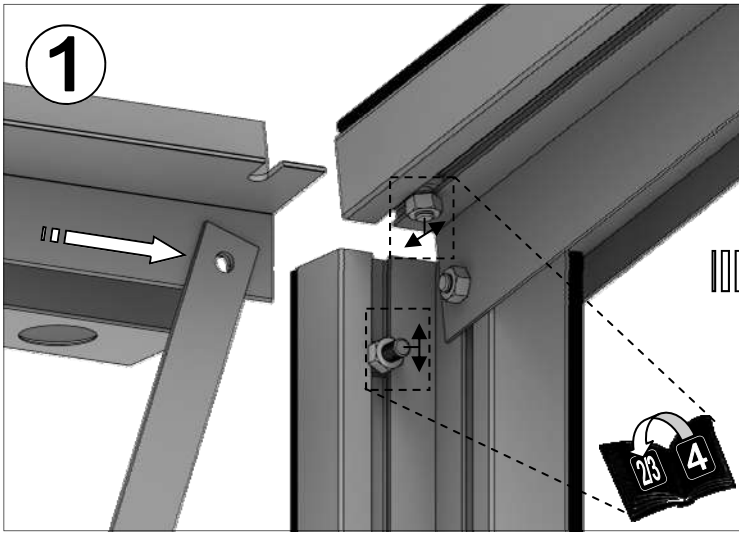

6'		
Part No	mm	Quantity
D976	1897	1
D951	1915	2
D593	1897	1
RUBBER	1000	8

8'		
Part No	mm	Quantity
D973	2517	1
D951	1915	3
D594	2517	1
RUBBER	1000	12

10'		
Part No	mm	Quantity
D981	3137	1
D951	1915	4
D595	3137	1
RUBBER	1000	16

12'		
Part No	mm	Quantity
D977	3757	1
D951	1915	5
D596	3757	1
RUBBER	1000	20

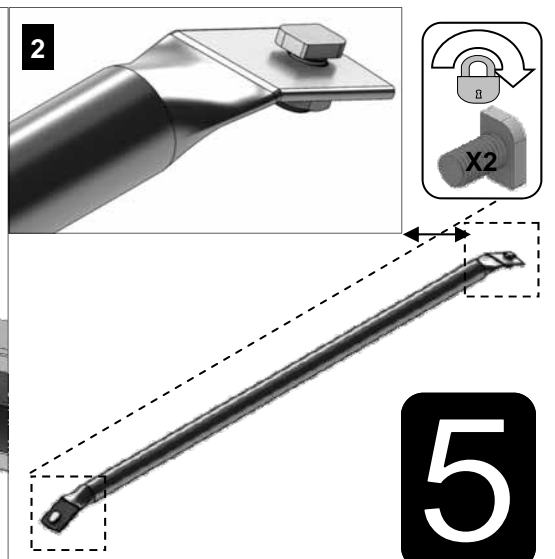
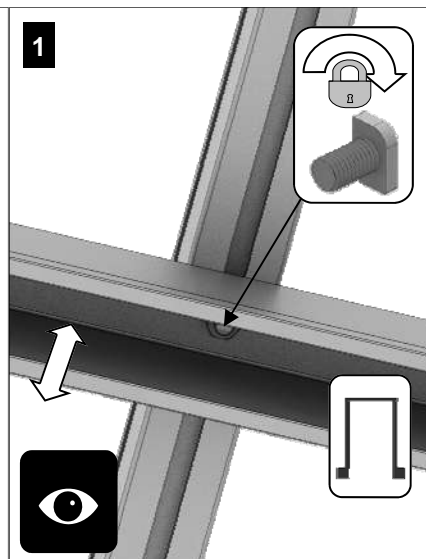
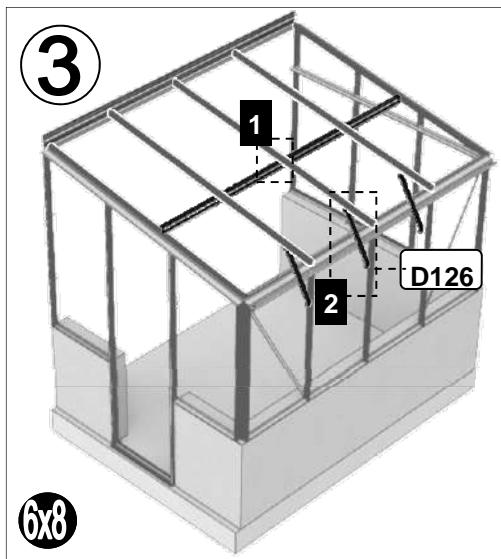
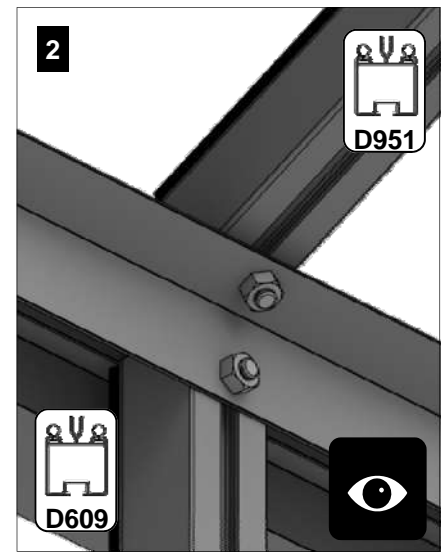
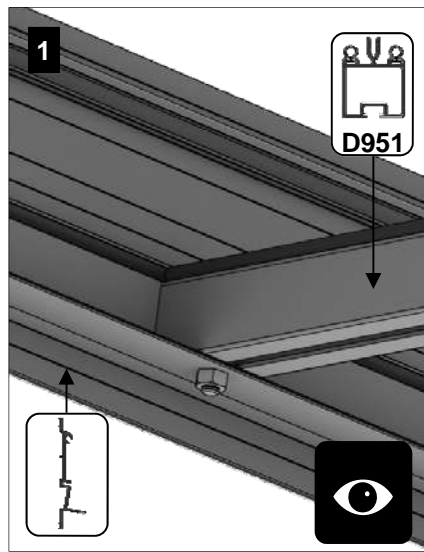
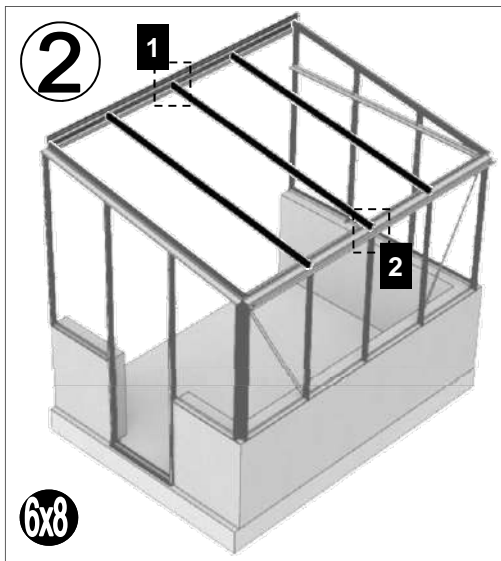
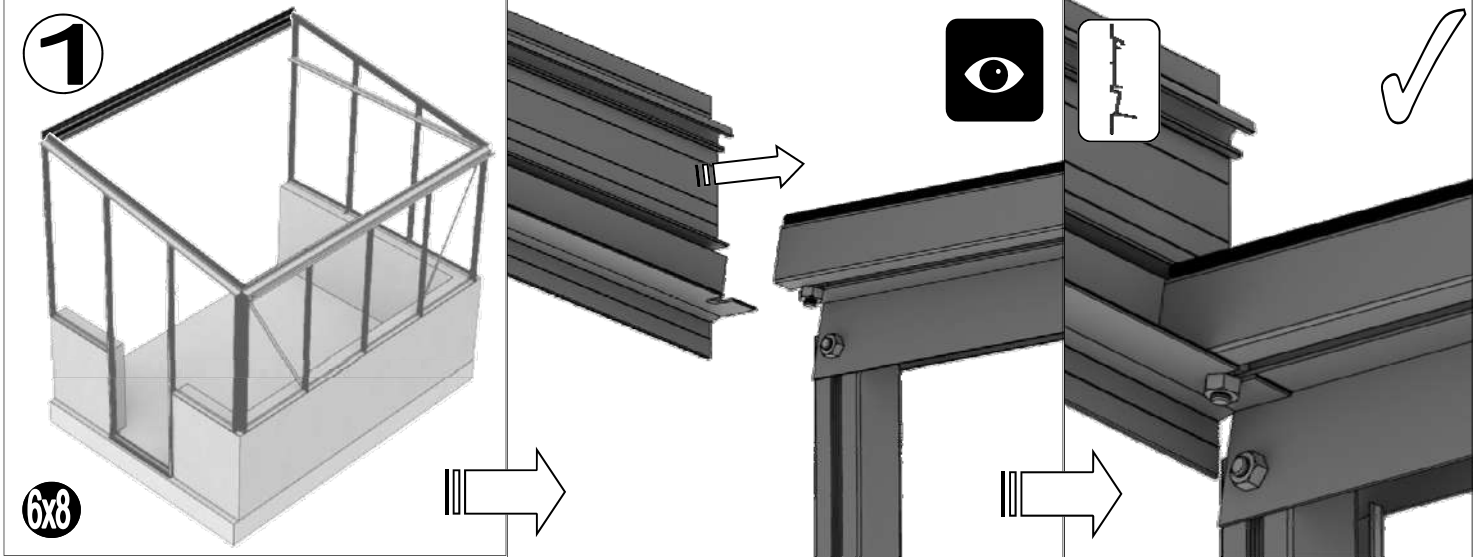

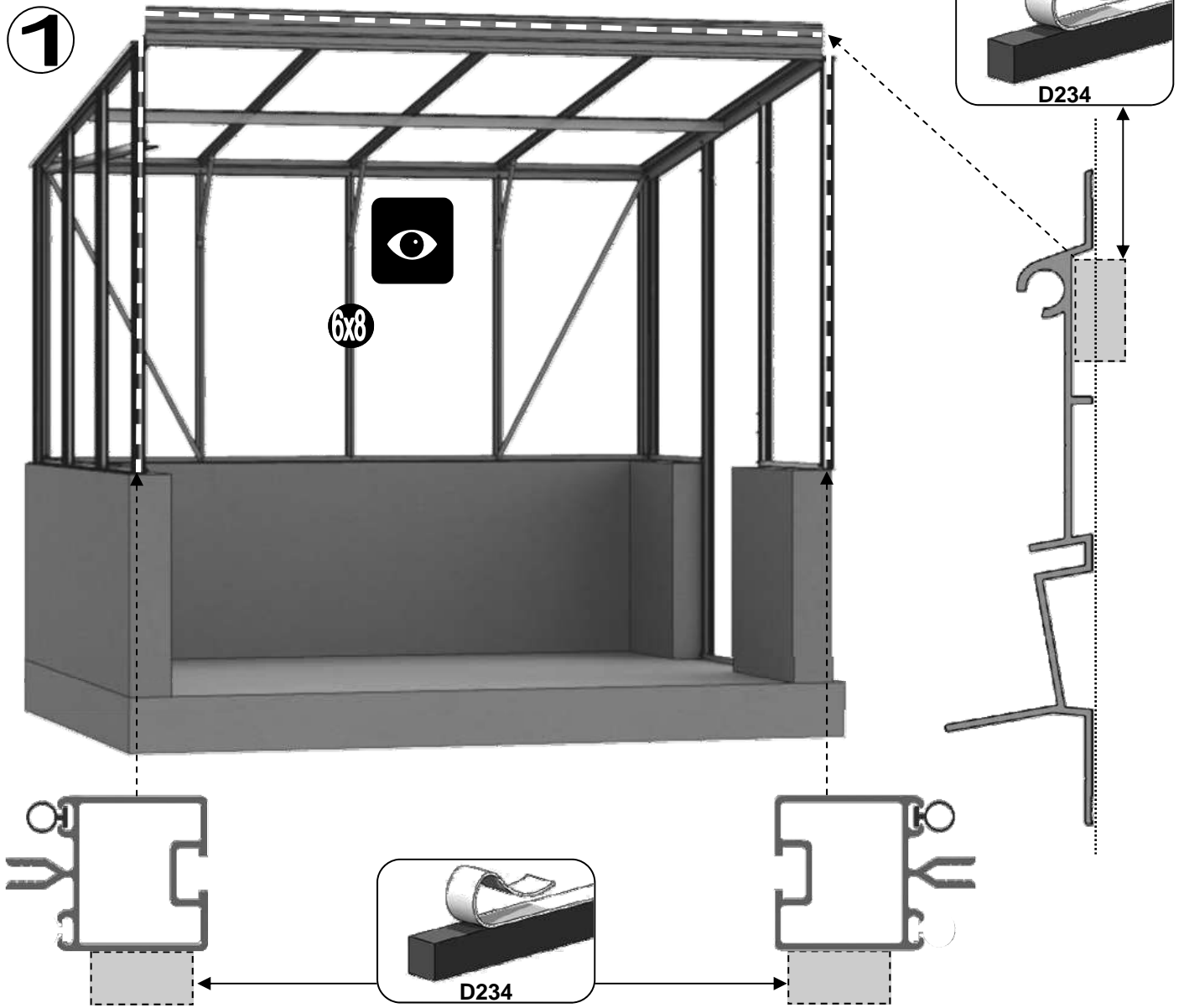

1

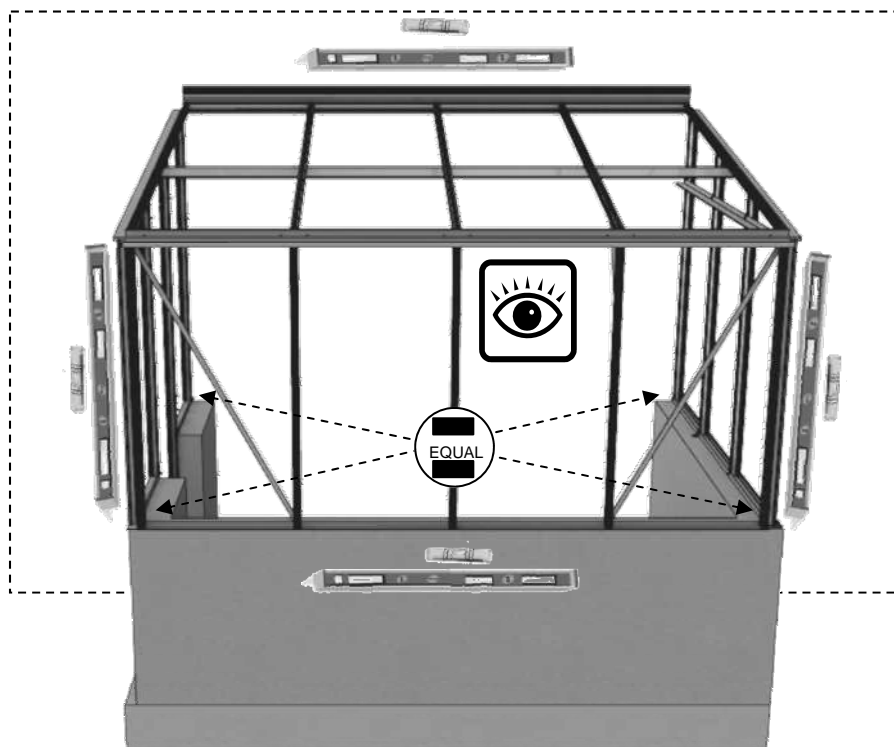

2



6

		6x6	6x8	6x10	6x12	
Part No		mm	Quantity			
SYSCR3		75	9	10	11	12
SYRAWL		50	9	10	11	12



3

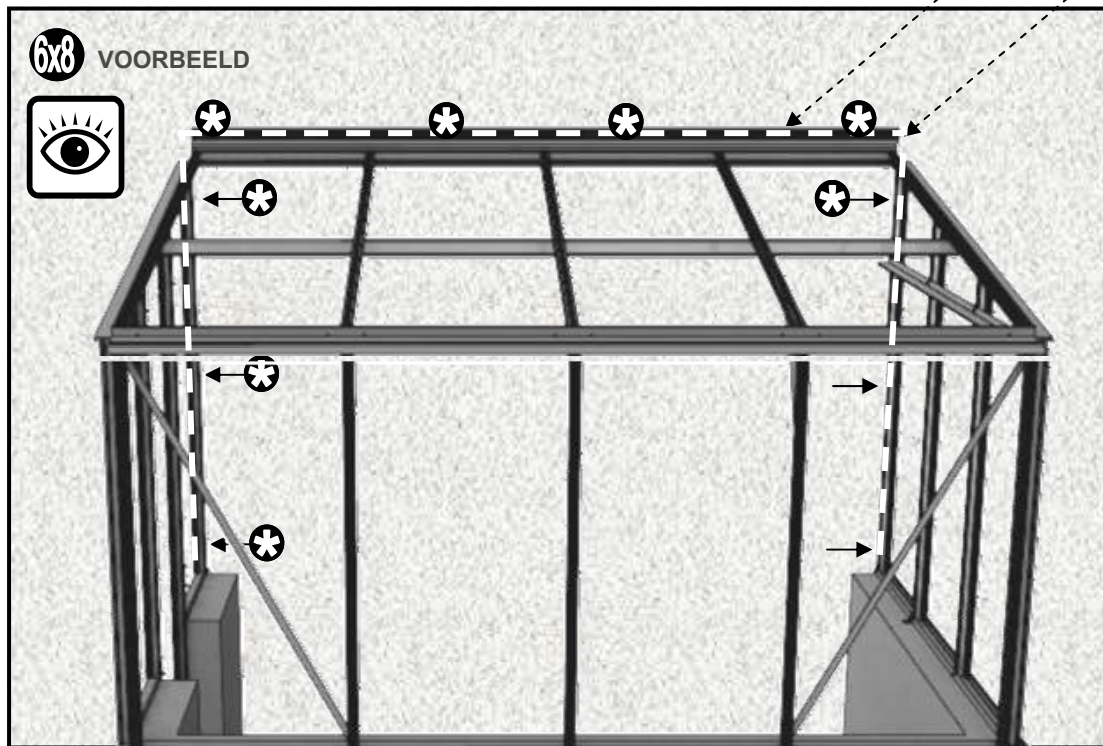

BELANGRIJK: ZET HET FRAME NIET VAST AAN DE FUNDERING. DIT GEBEURT PAS BIJ FASE 12. ZET NU ALLEEN DE NOK VAST TEGEN DE MUUR.

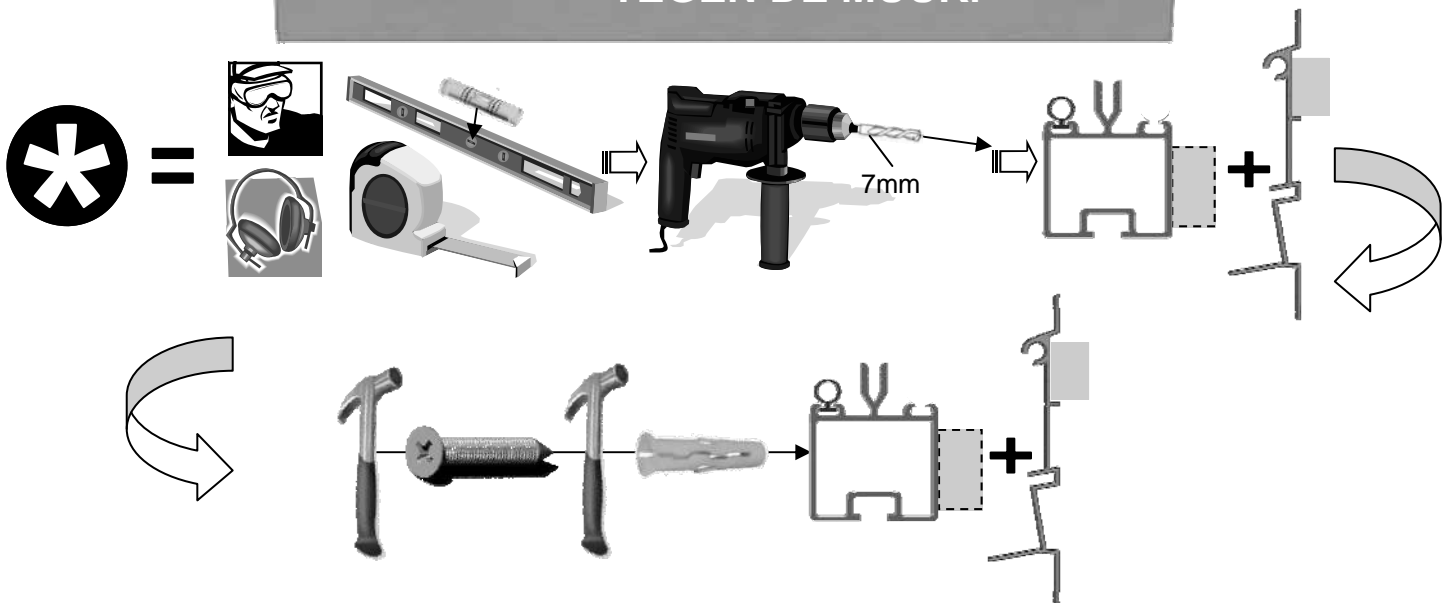

Om het frame te bevestigen aan de muur, gebruikt u L-vormige beugels en 2 schroeven, dit is vergelijkbaar met het verankeren van de tuinkas (zie hoofdstuk 12).

6



1 Dakraam = {



D1208
1 of -
610 x 610
glasplaat

Part No		mm	Quantity
D866		639	1
D863L		613	1
D863R		613	1
D862		593	1

Part No		mm	Quantity
D220 PLUS FS6060 SCREW		N/A	2
D205		N/A	2
SY-BOLM6X11		10	4
SYNUTM6		M6	4
8 X 12 S/T FS6017		10	2
8 x 19 S/T FS6018		19	2

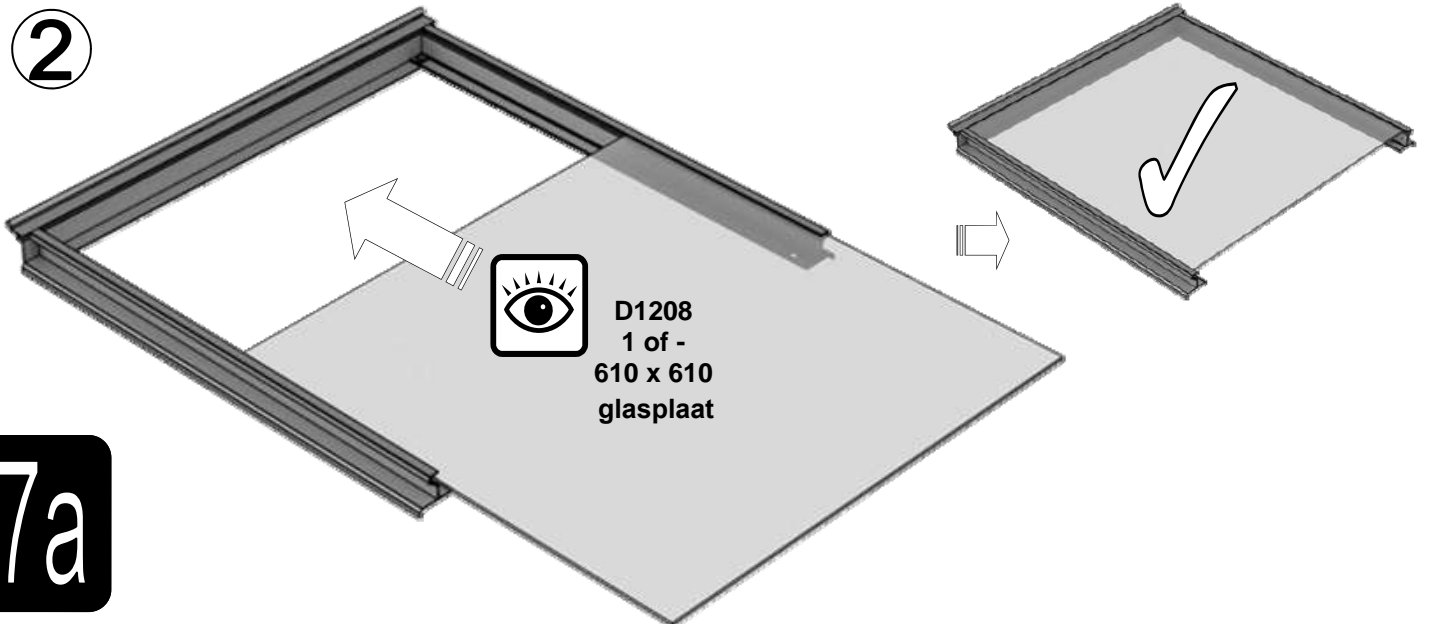
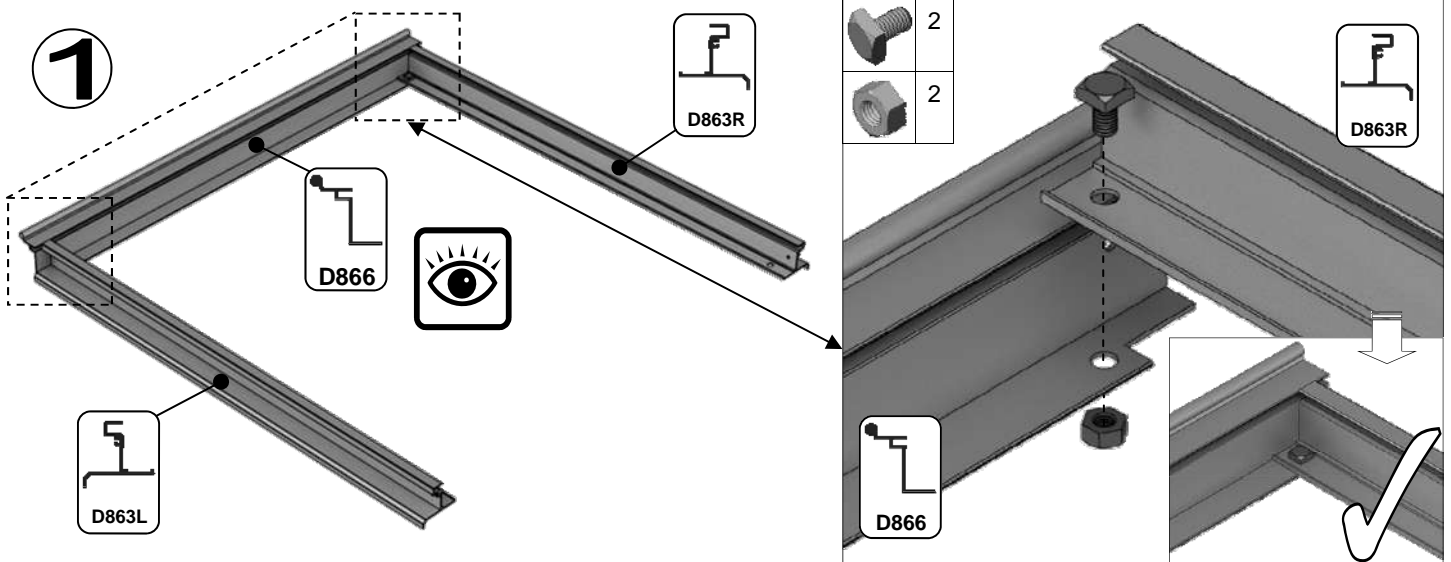

7a

3 

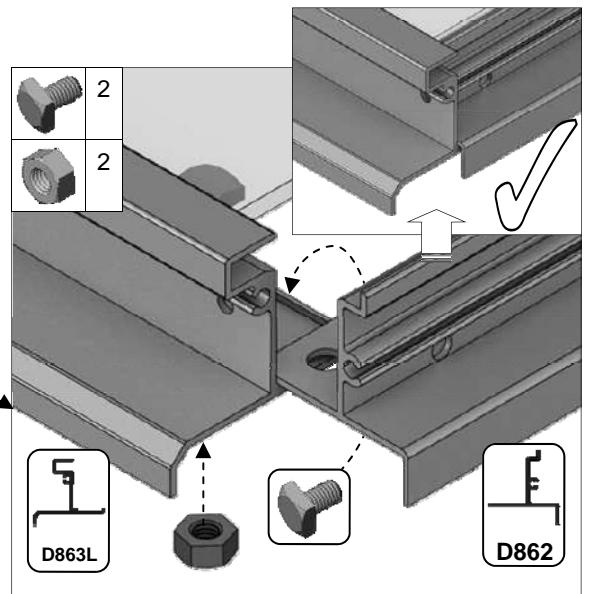
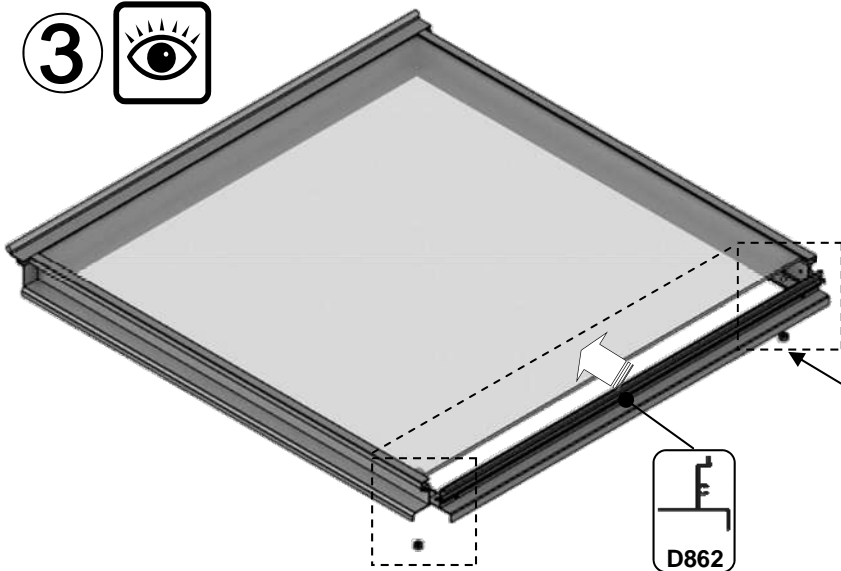

4 

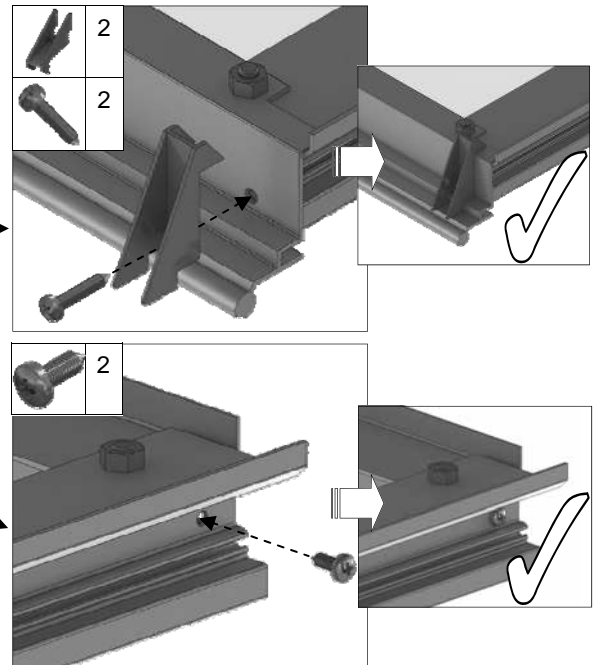
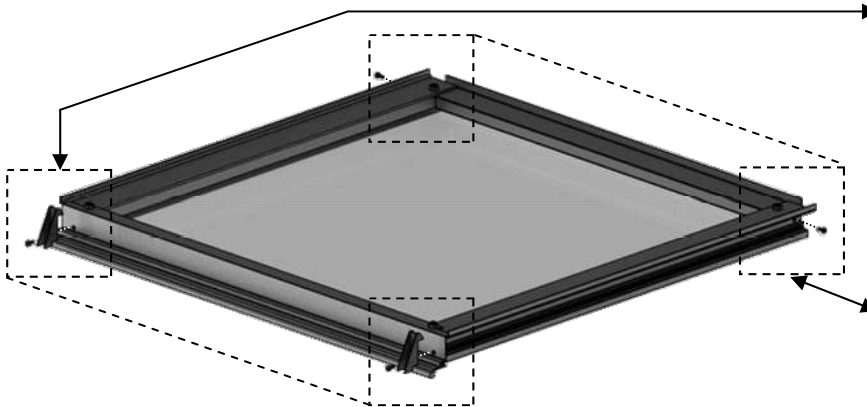
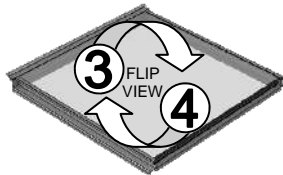

5 

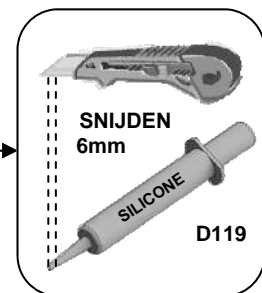
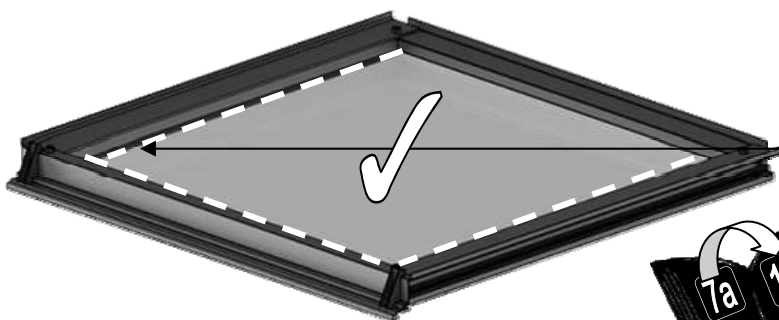

7a

1 Raamdorpel = {

Part No		mm	Quantity
SY-BOLM6X11		10	2
SY-BOLM6X15		15	2
SYBOLM6 X11CROP		10	2
SYNUTM6		N/A	4

Part No		mm	Quantity
D079 PLUS FLUFF		590	1
D114		N/A	2

6

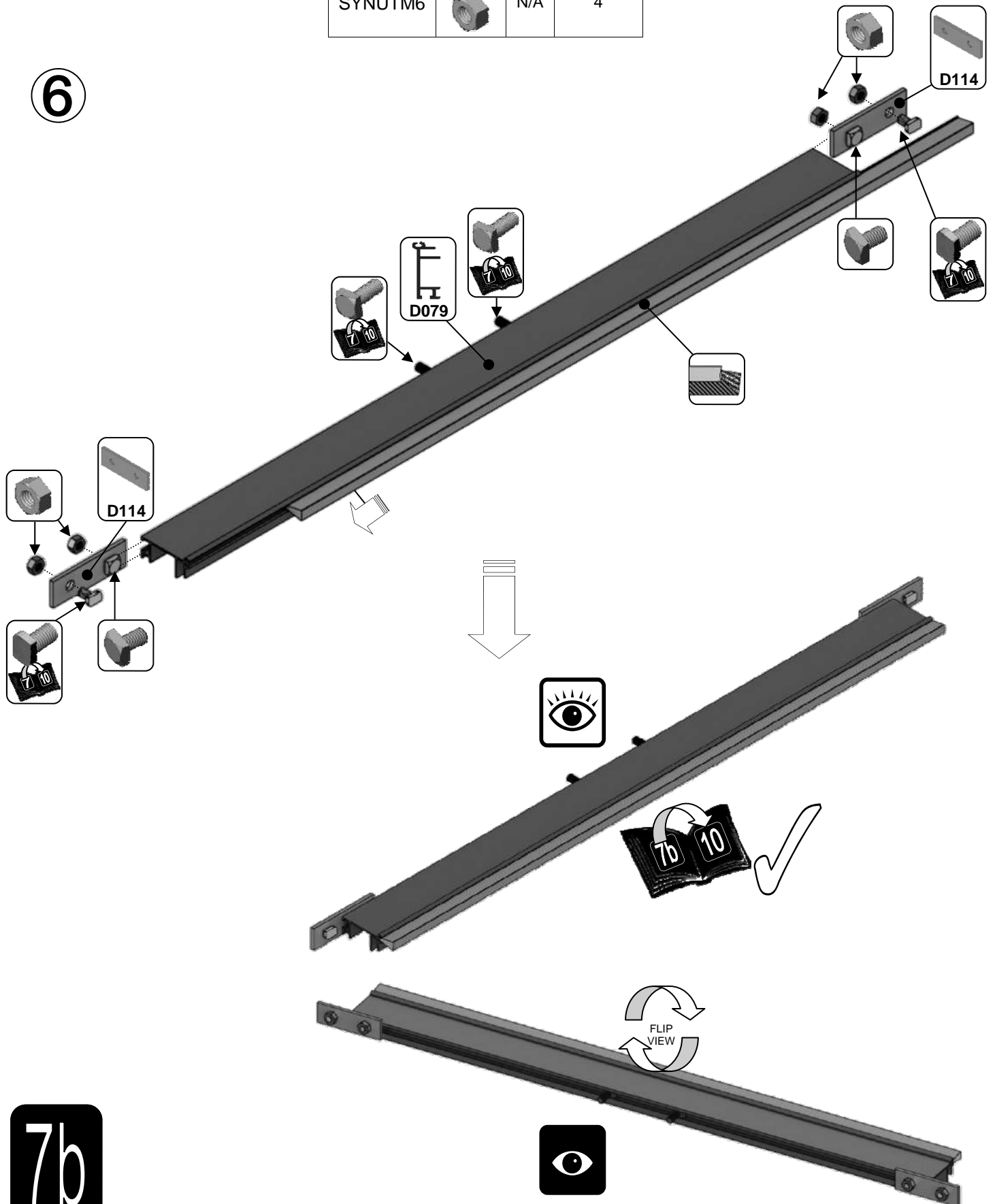

7b

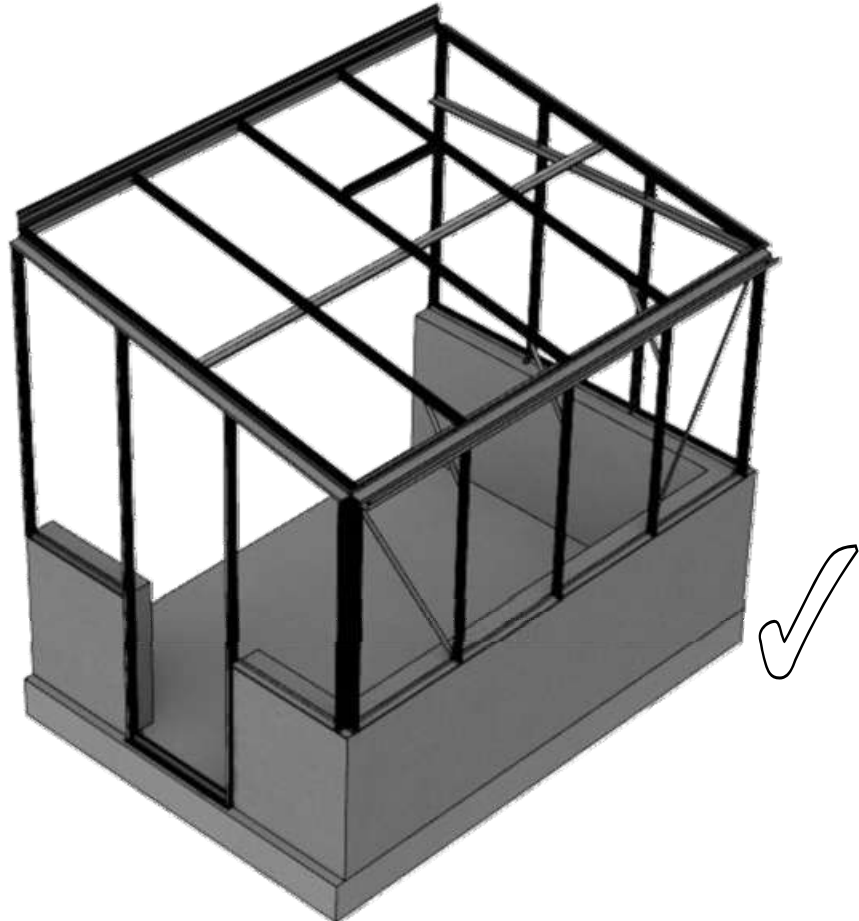
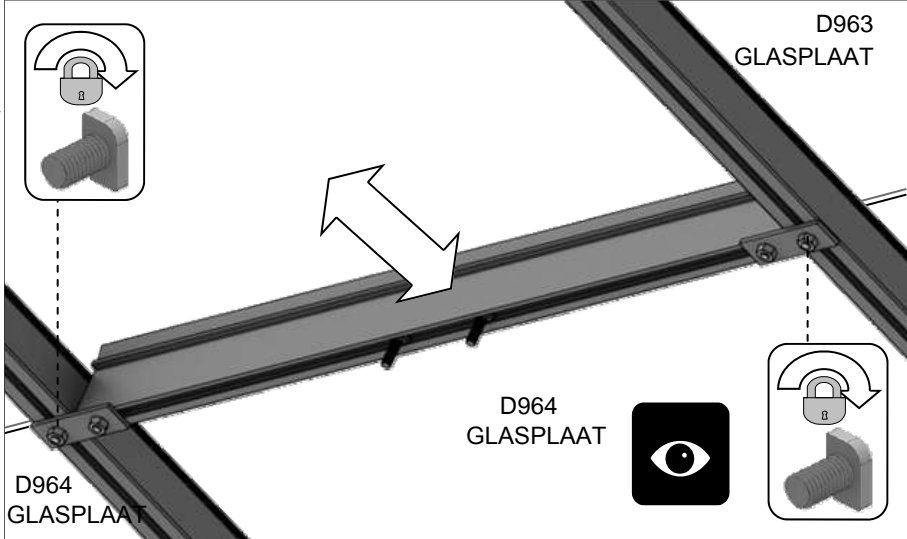
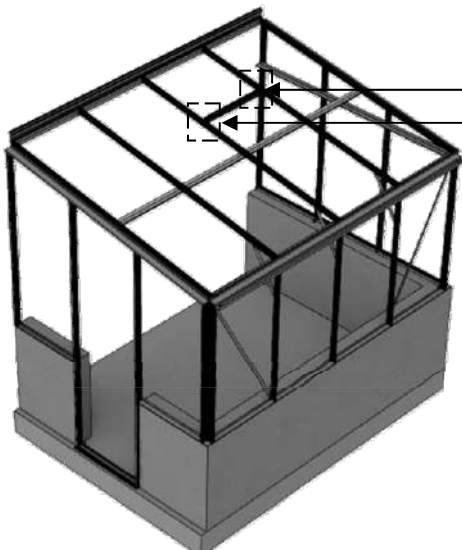
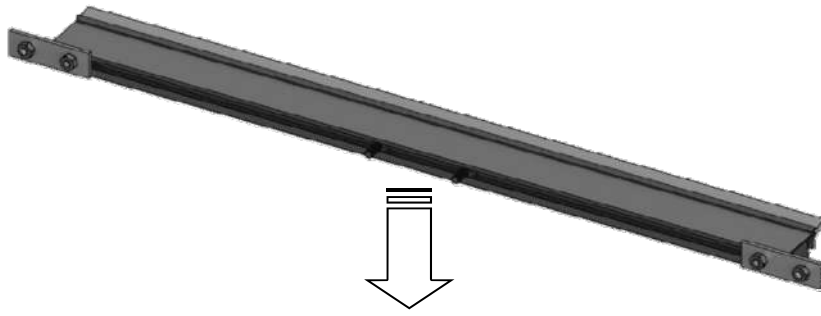



Part No		mm	Q
D090 + D347 lock = D301		1824	1
D094		1824	1
D096 + D217 wheel = D307		611	1
D095		611	1
D097		611	1

Part No		mm	Q
D232		905	2
D233		797	2
P053		N/A	1
D225		610	1
D840B		4000	1
D263 PACK		N/A	7
		N/A	7
D260 PACK		N/A	12

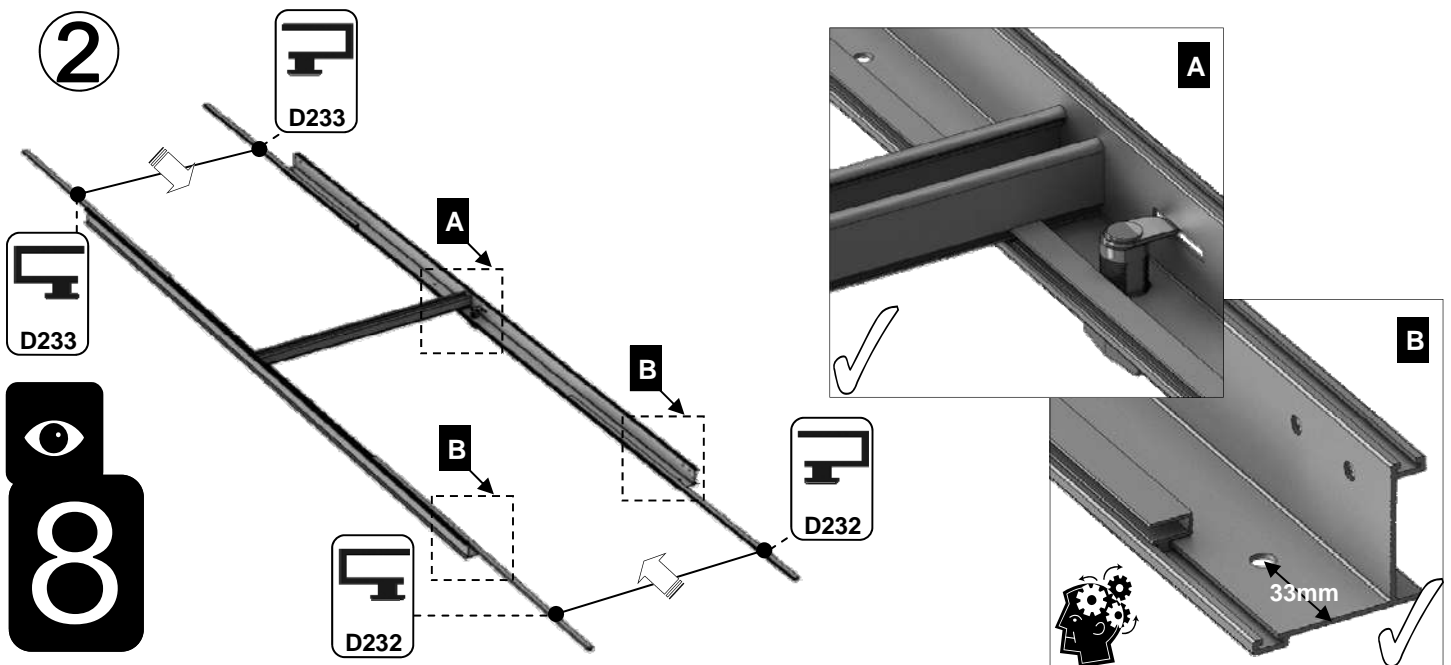
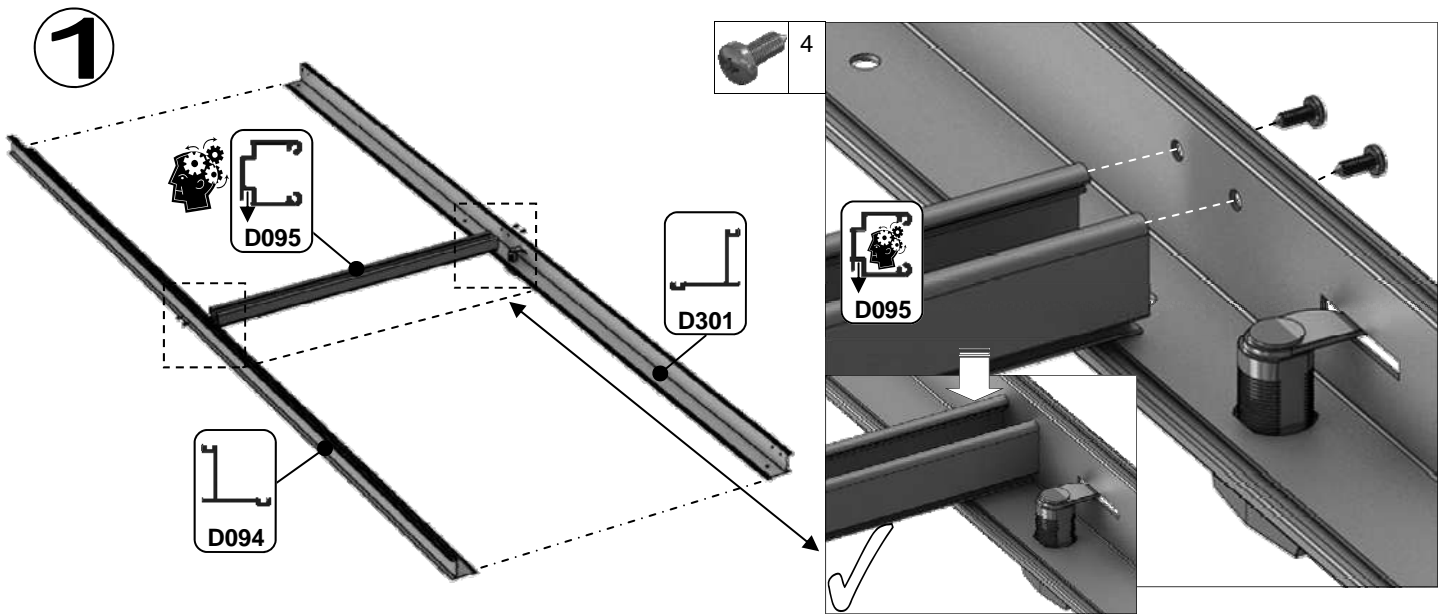

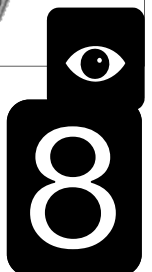
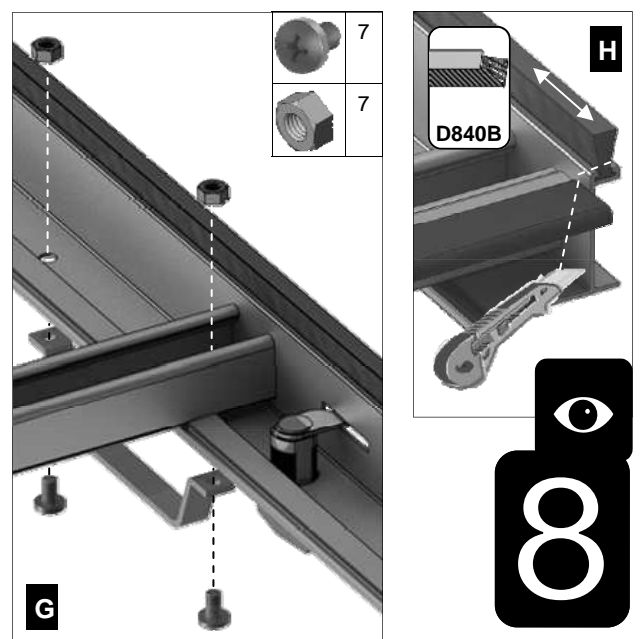
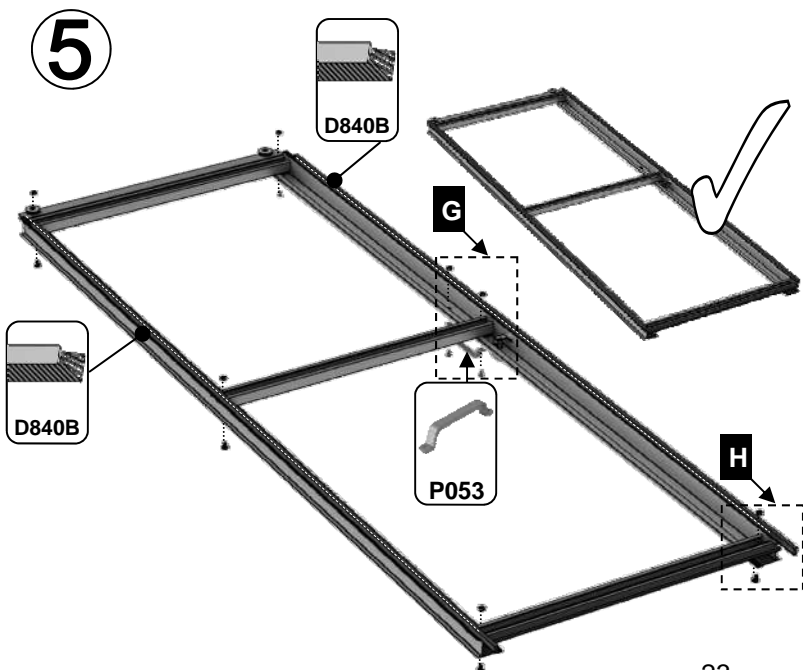
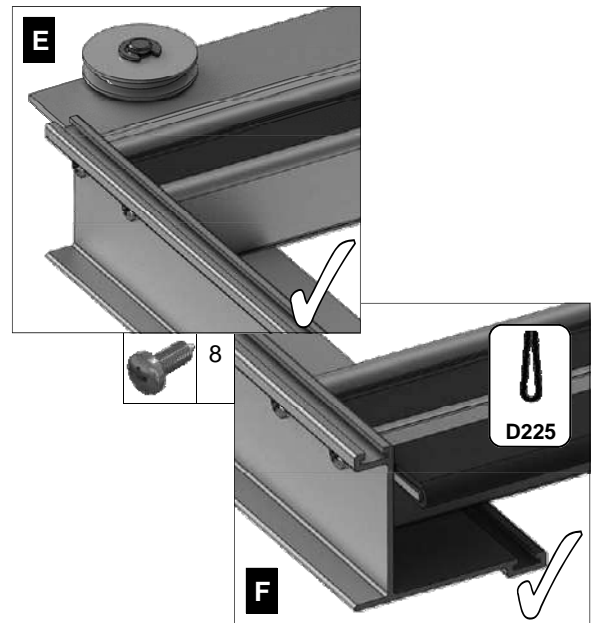
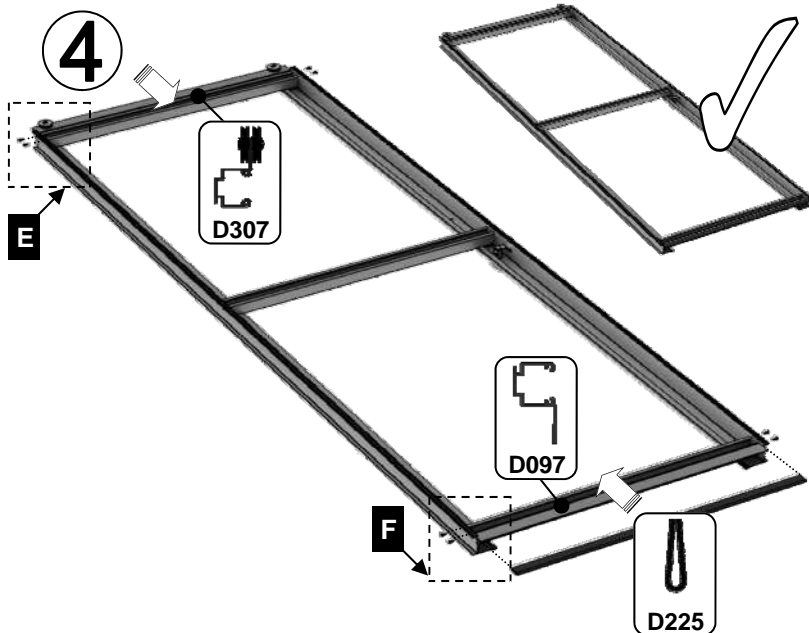
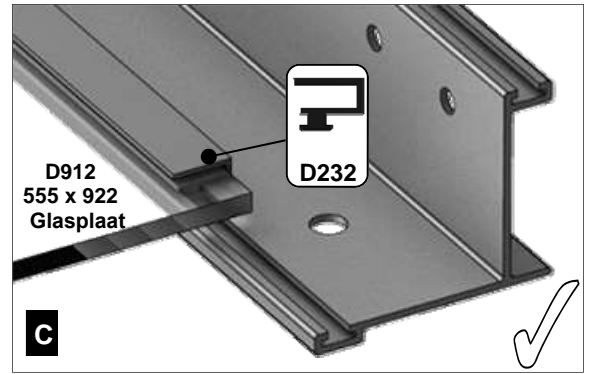
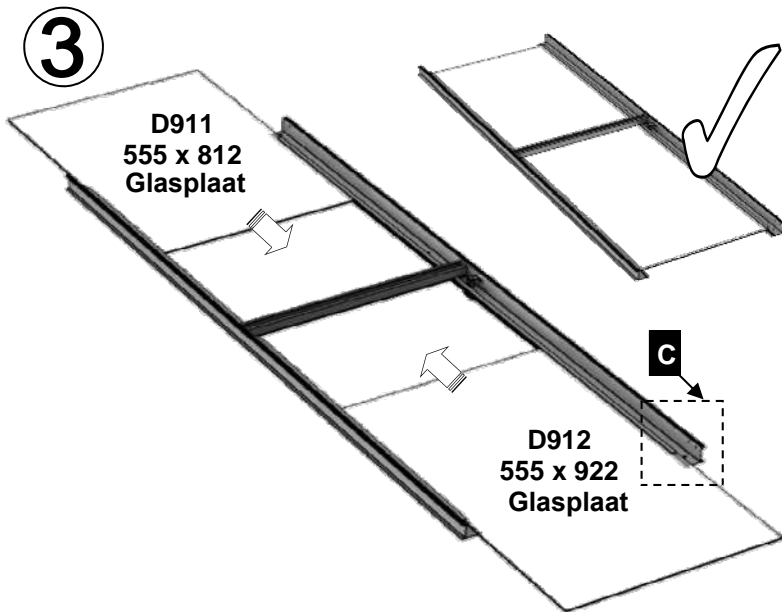

PART No	Section	Size (mm)
D541		1915
D618		1144
D969		140
D971		250
D987		1370
D991	1260	
D547		1915
D610		1160
D620		1144
D814		1883
D986	1480	
D544		1915
D614		1162
D619		1144
D836		1883
D970		140
D972		250
D988		1370
D989	1480	
D990	1260	



VOORBEELD

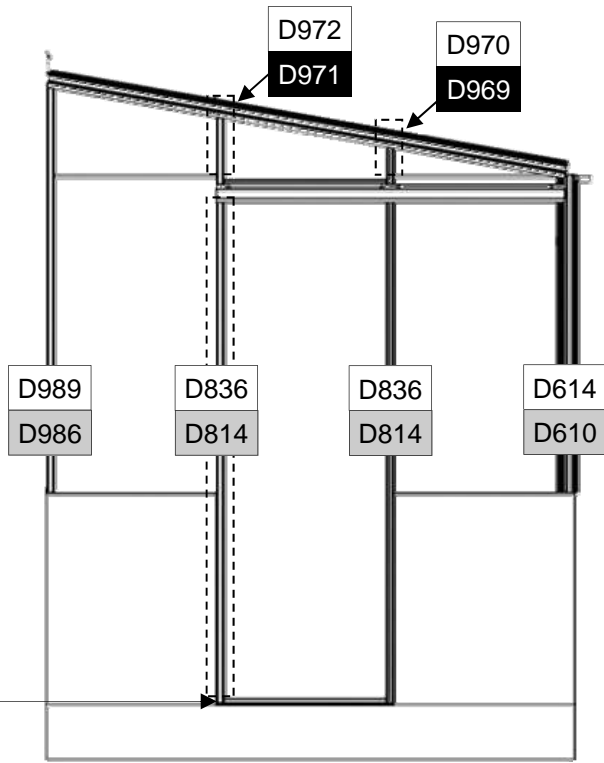

VOORBEELD

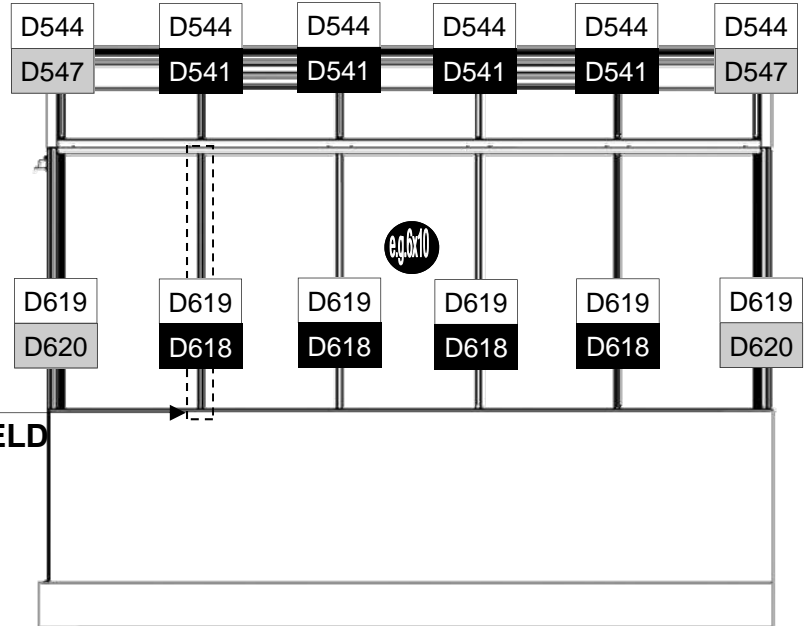
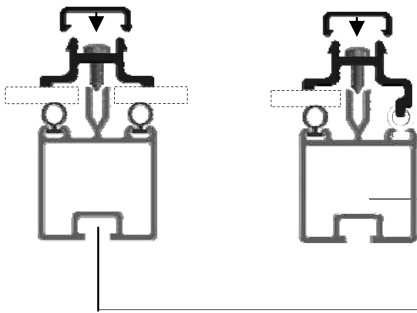

VOORBEELD

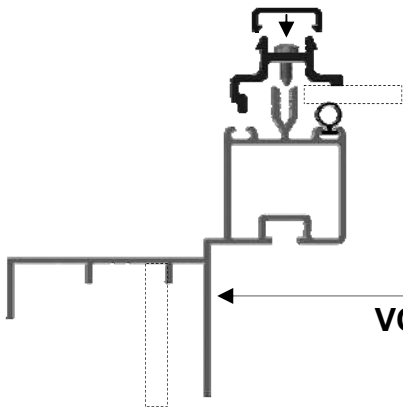

VOORBEELD

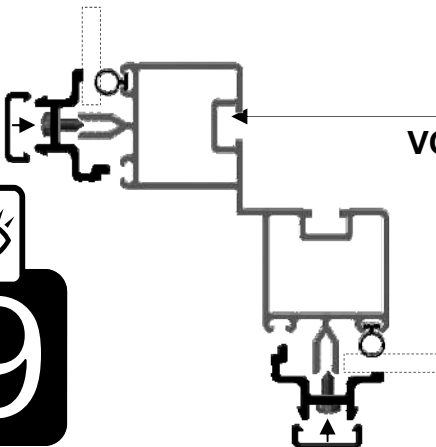

VOORBEELD

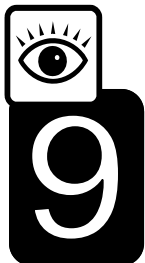
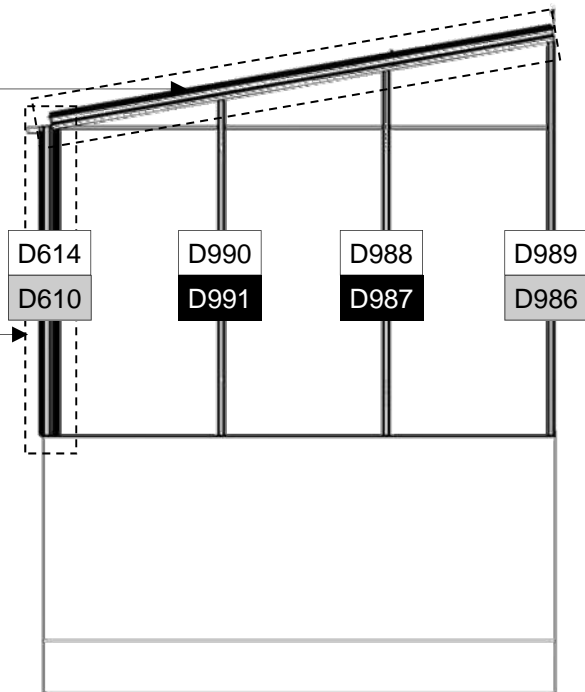

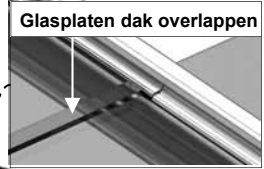
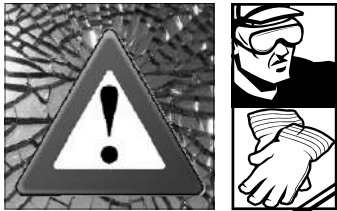

VOORBEELD

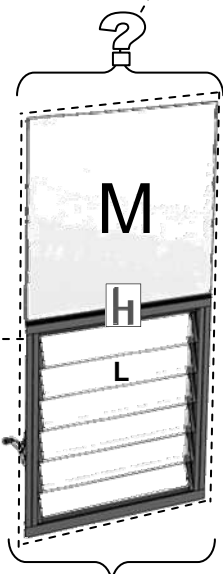
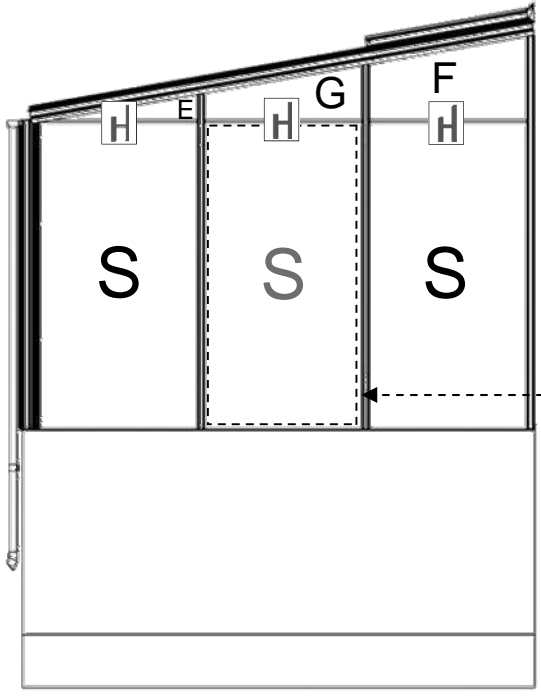
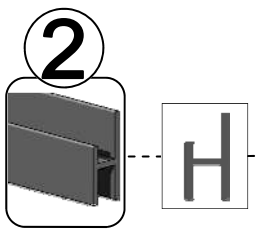
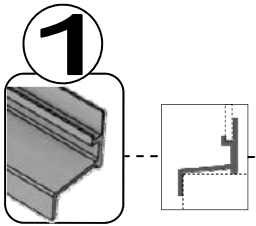
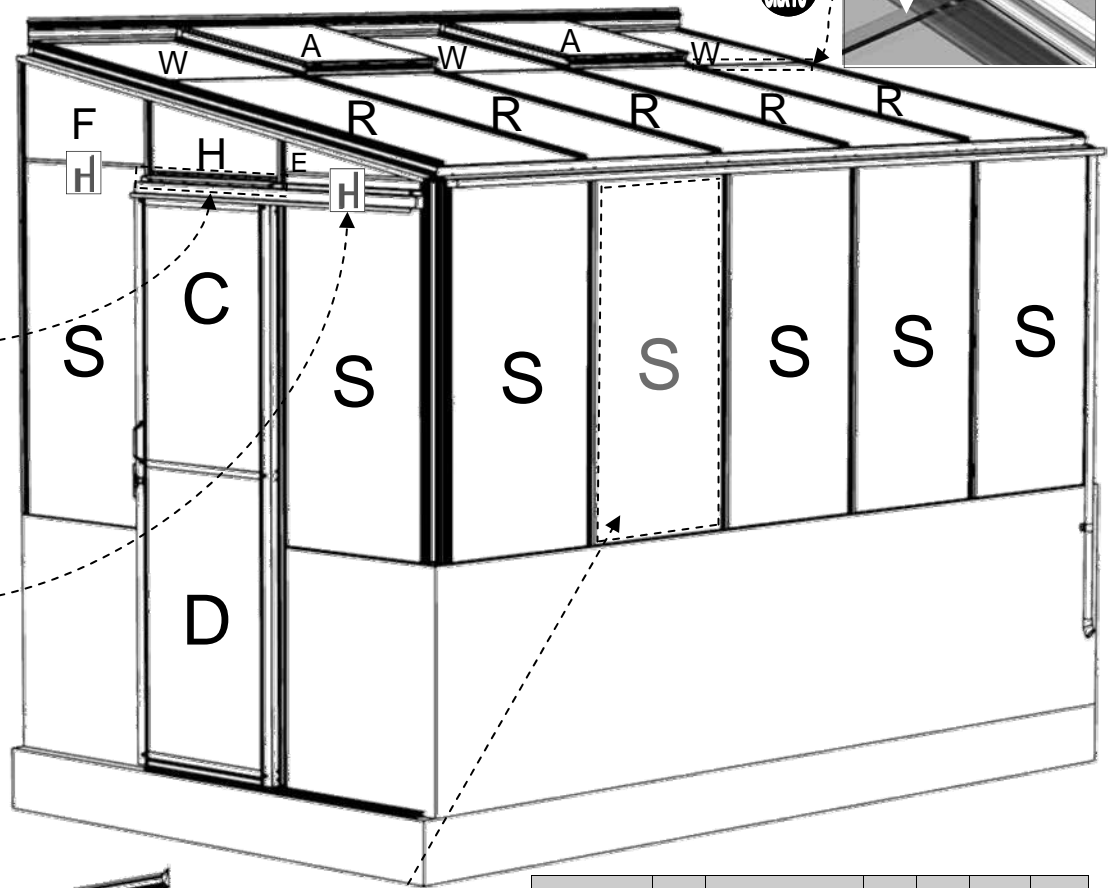

PART No		Size (mm)	6'	8'	10'	12'
D1216	S	610 X 1162	7	8	9	9
D964	R	610 X 1312	3	4	5	6
D963	W	610 X 630	2	3	3	4
D1208	A	610 X 610	1	1	2	2
D911	C	555 X 812	1			
D912	D	555 X 922	1			
D965	F	ANGLE	2			
D966	E	ANGLE	2			
D967	G	ANGLE	1			
D968	H	ANGLE	1			
D222/B		590 long	1			
D101 / ROSEPS	H	610 long	5			





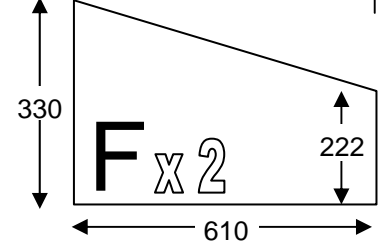
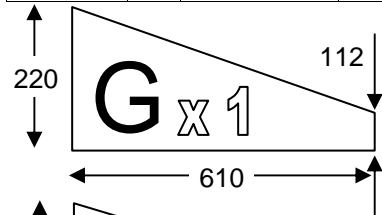
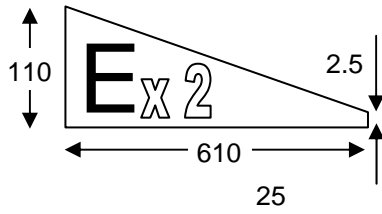
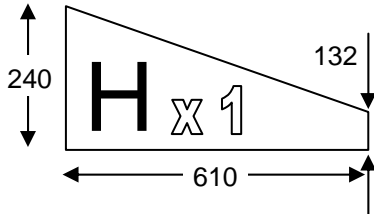

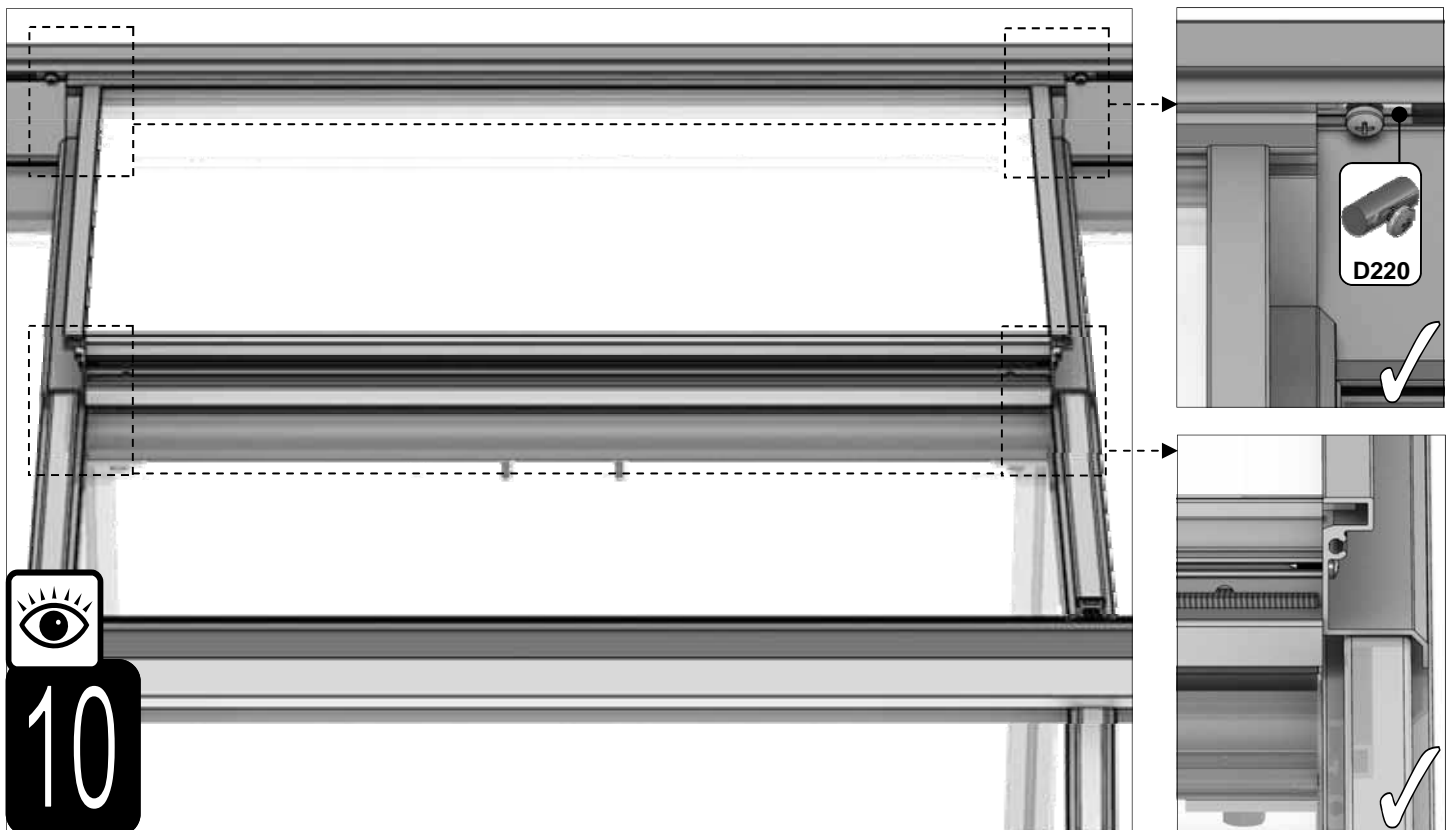
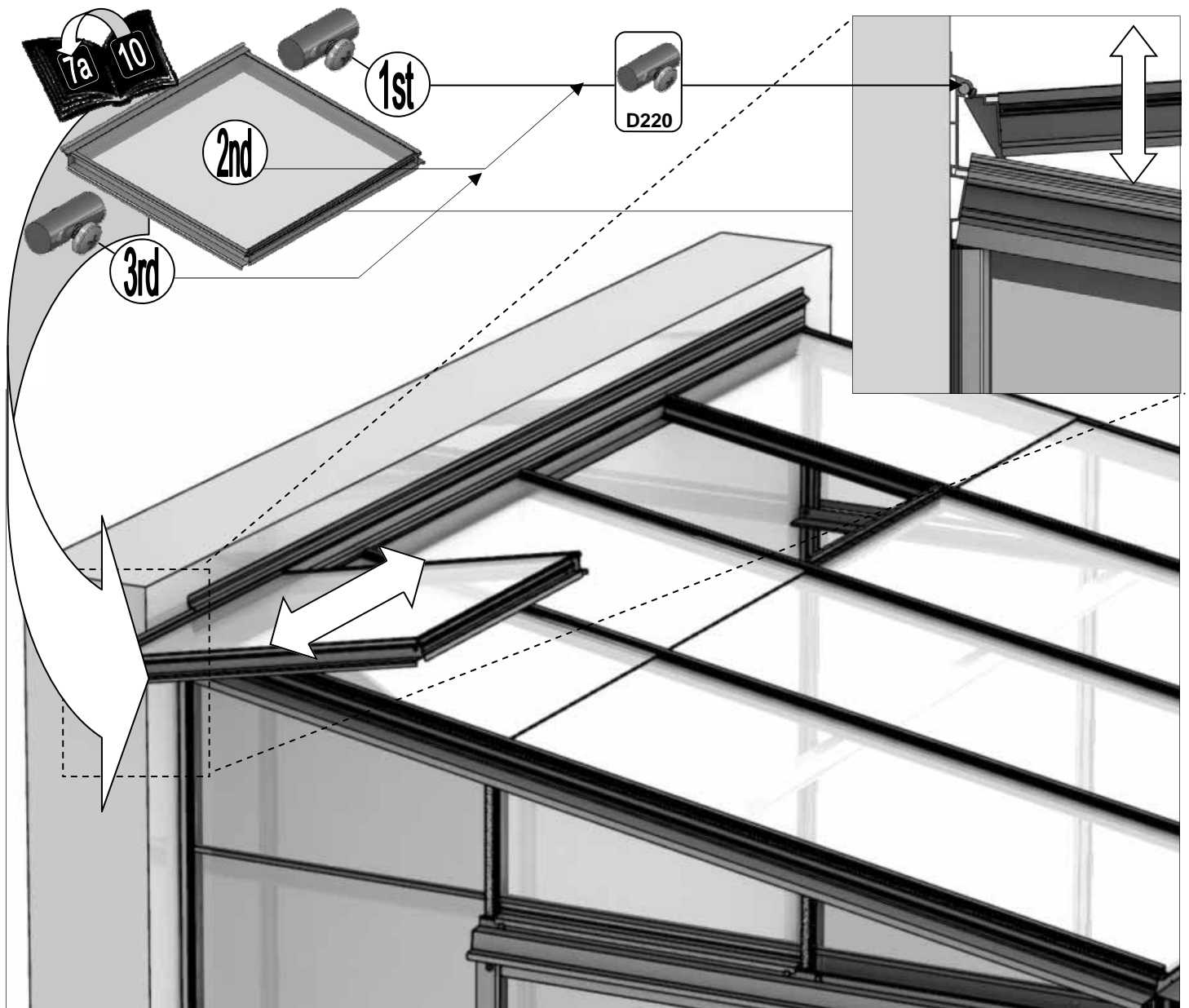

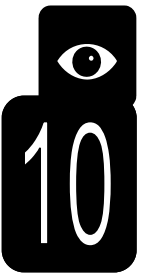
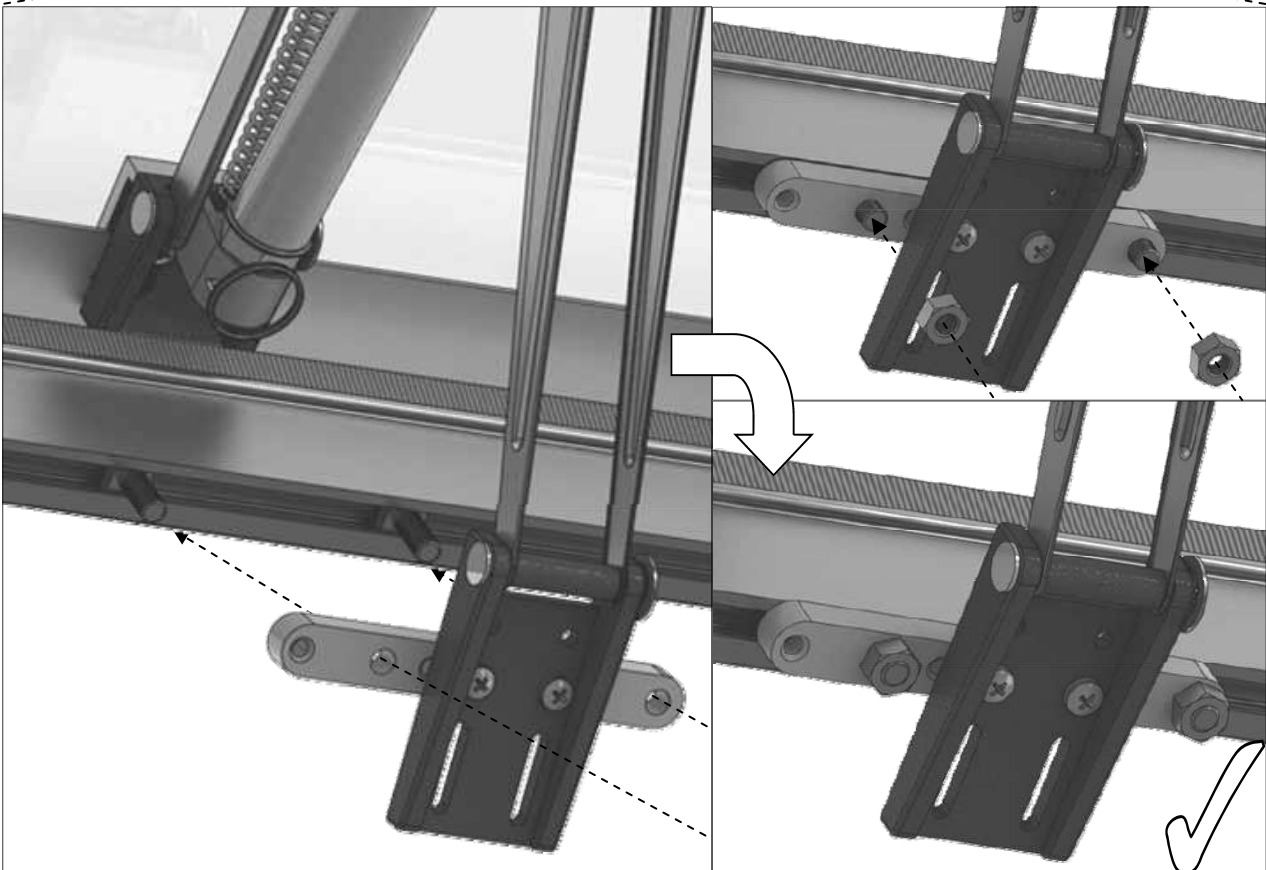
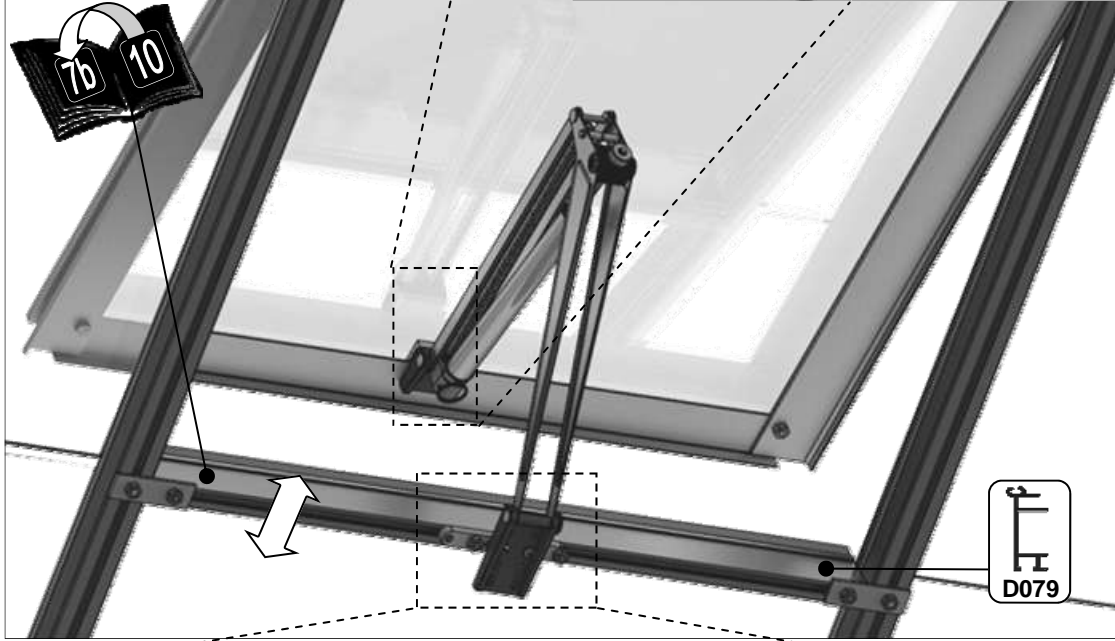
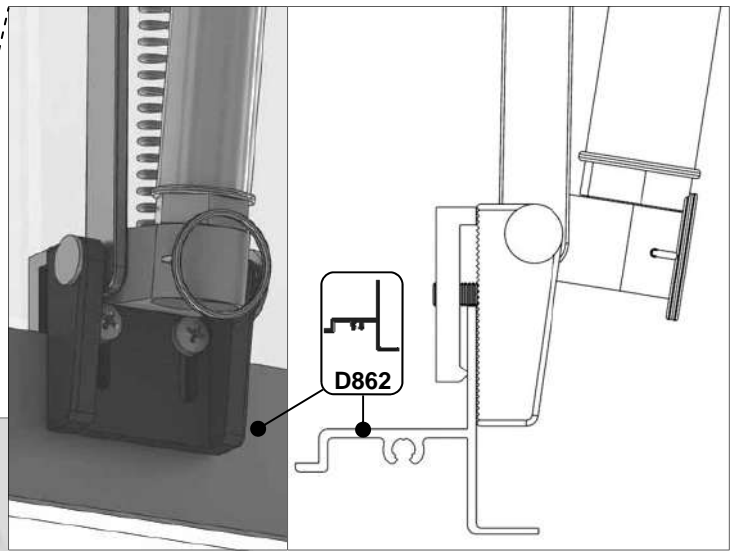
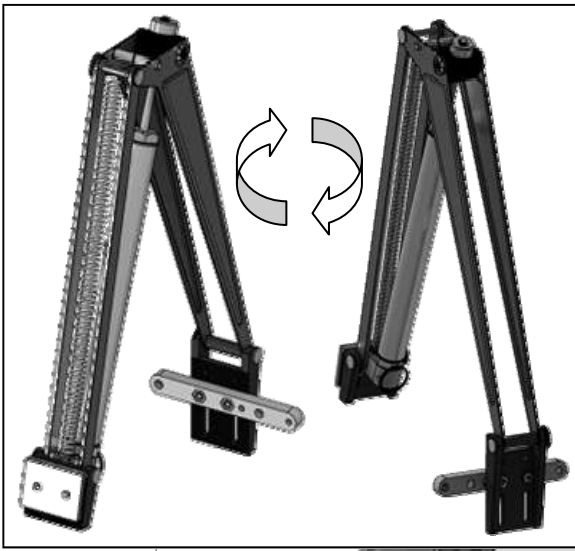
D624	M	610 X 550	1
D729	L	525 X 100	6
D101 / ROSEPS	H	610 long	1

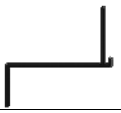





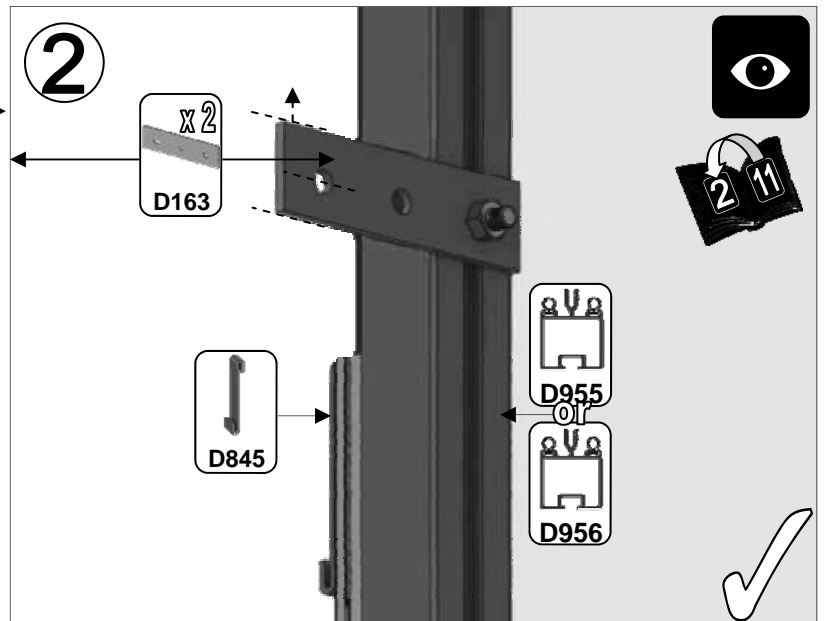
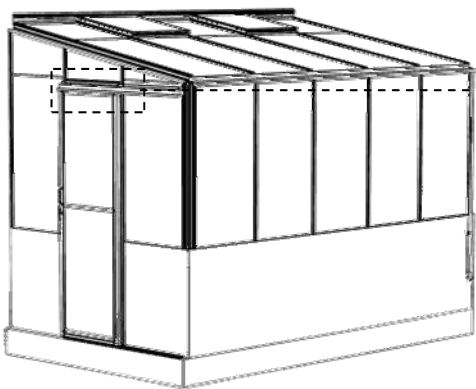
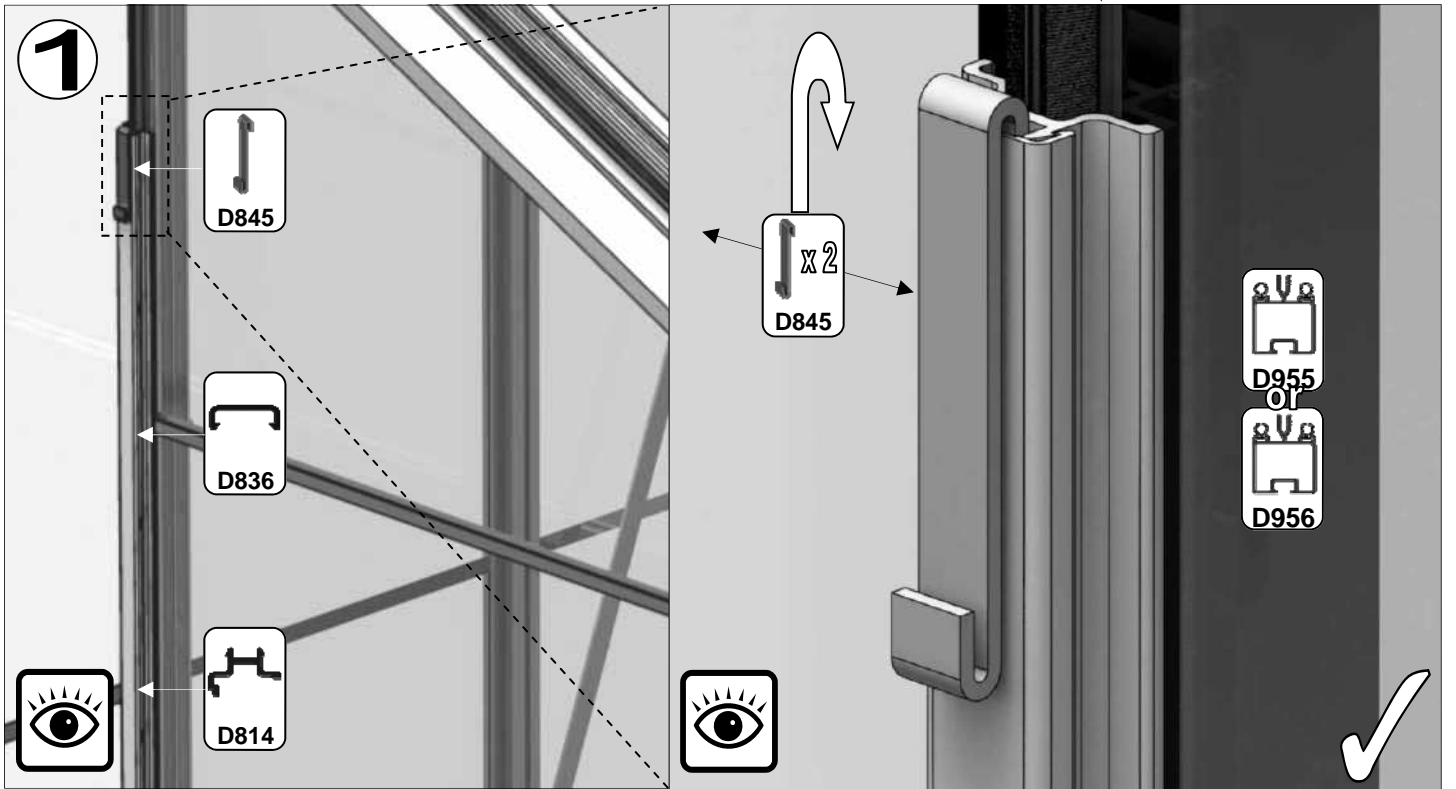
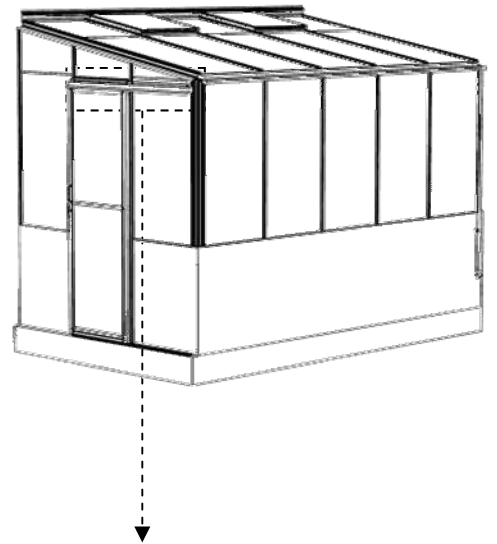

Part No		mm	Q
D864		590	1
D084		1270	1
D083		1270	1

Part No		mm	Q
D163		90	2
D845			2
SY-BOLM6X15			8
SYNUTM6			8

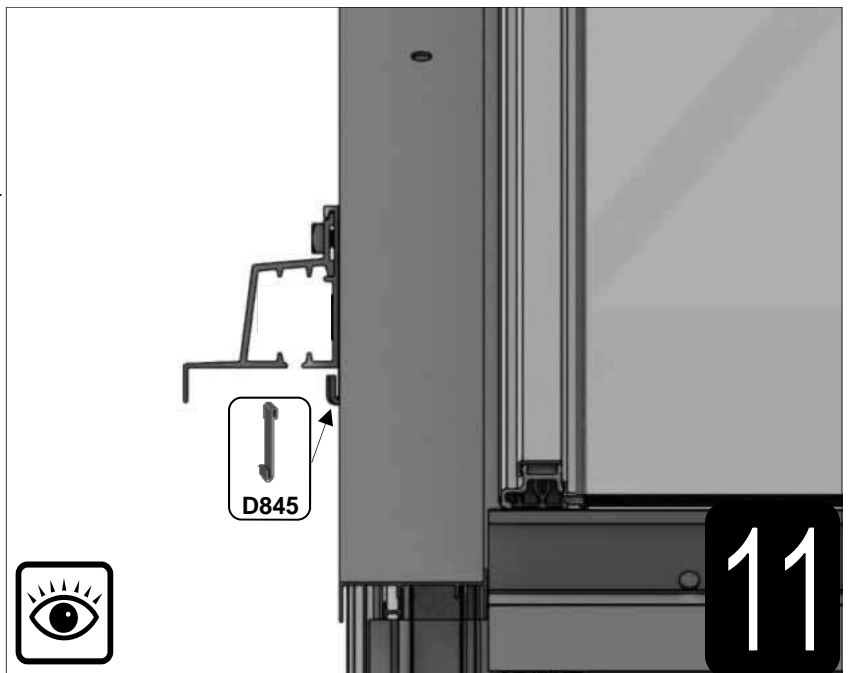
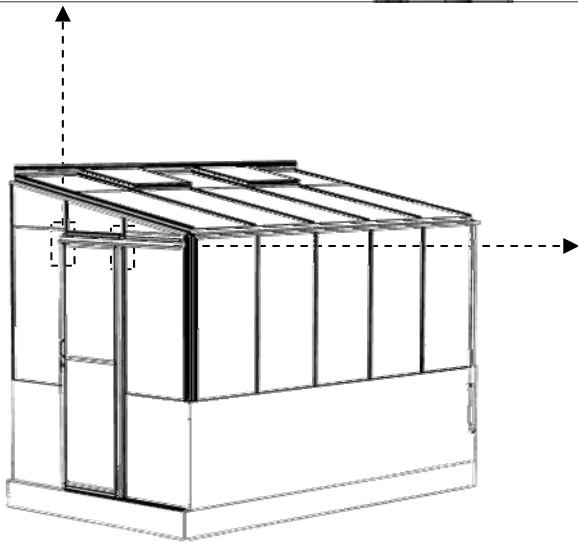
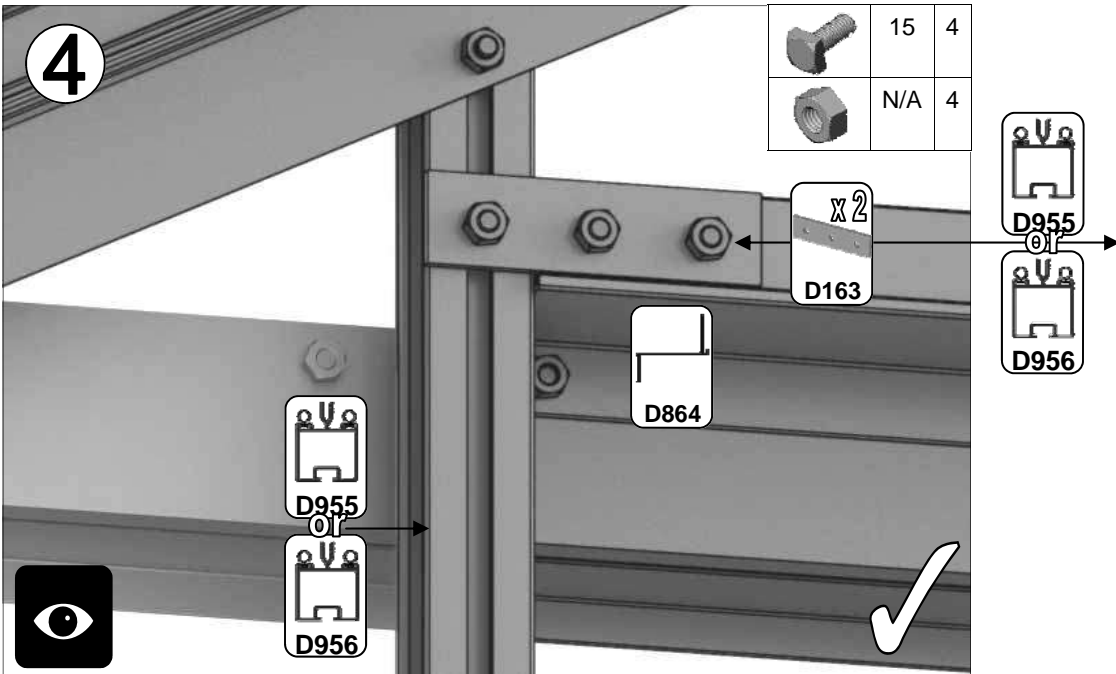
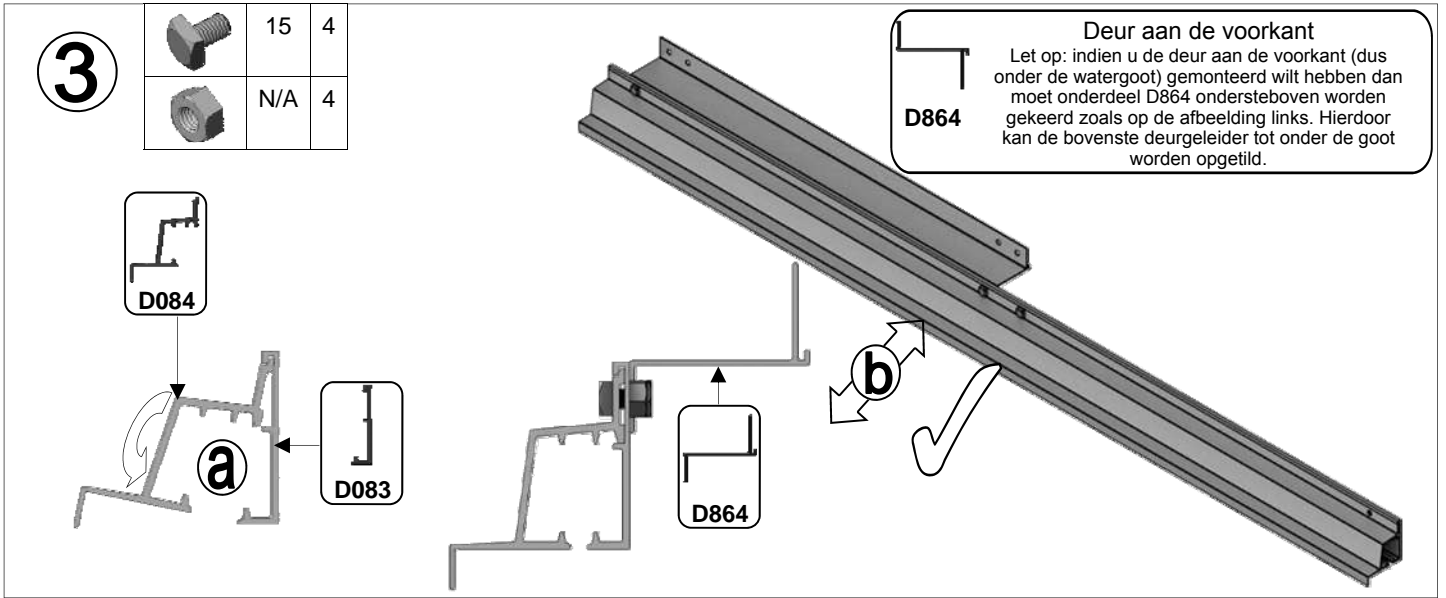

11

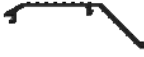

Part No		Q
D860		1
D087		1

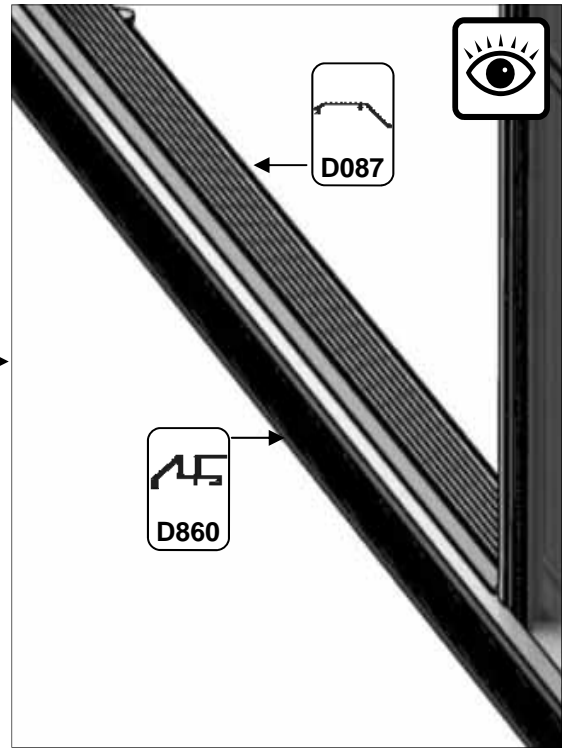
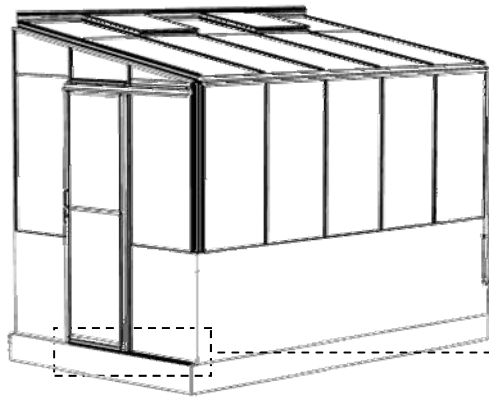

5

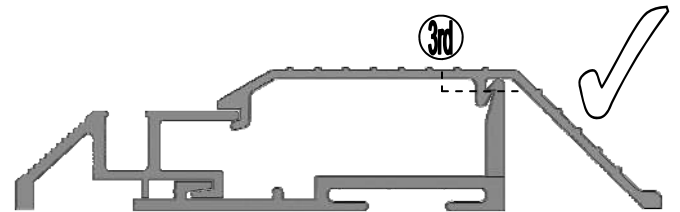
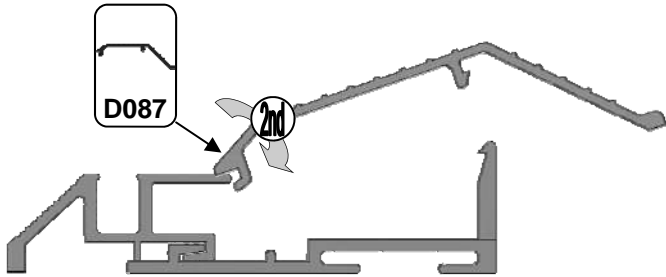
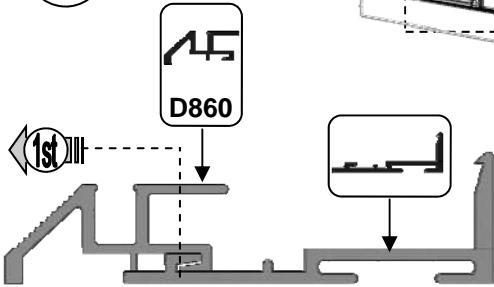

6

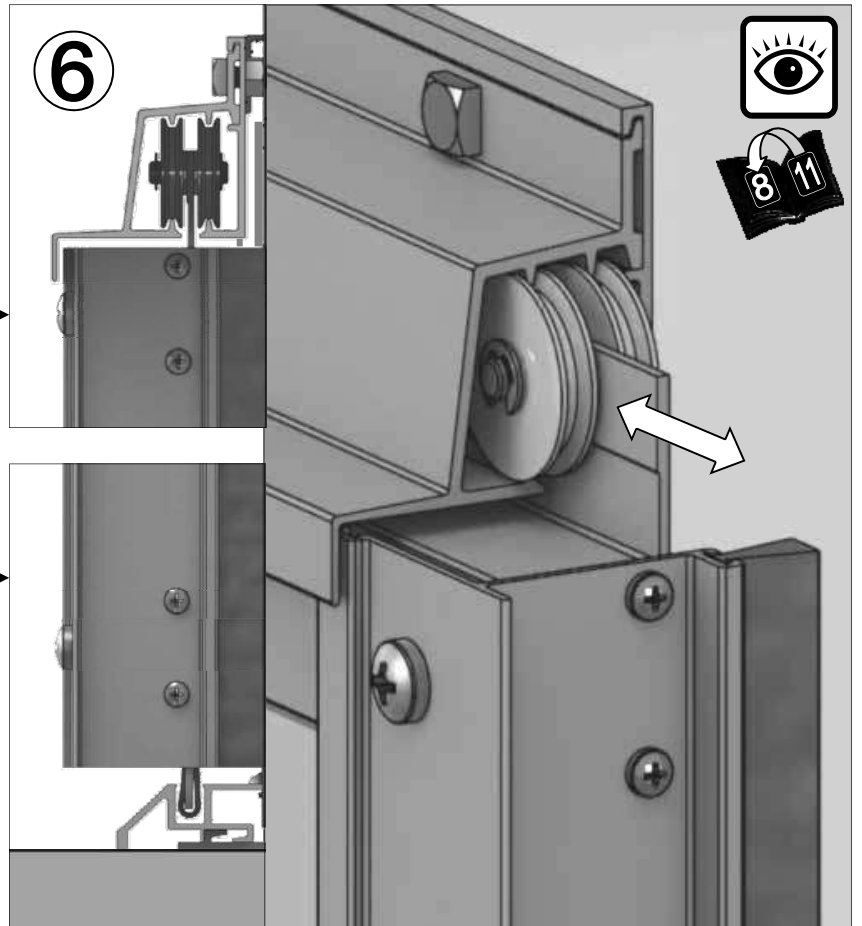

11

Part No		Q
D842		1
D112		1
SYBOLM6 X11CROP		3

7

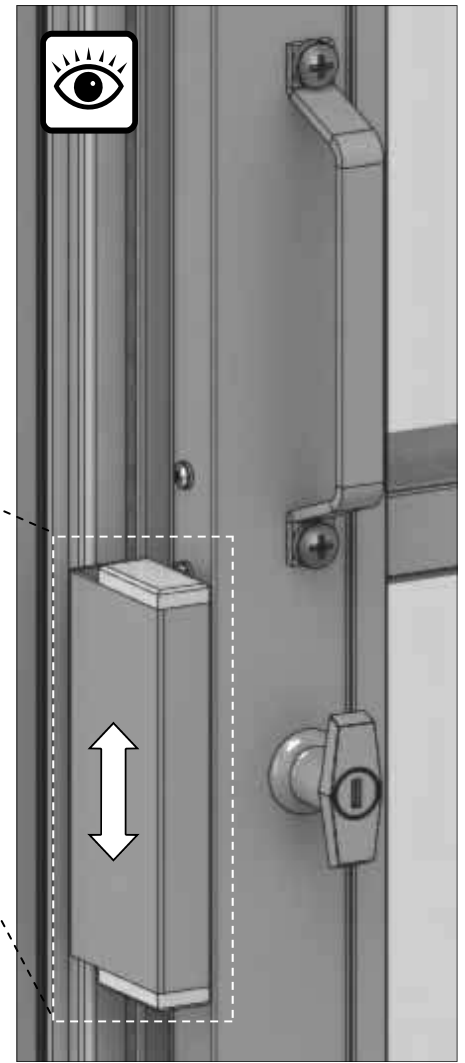
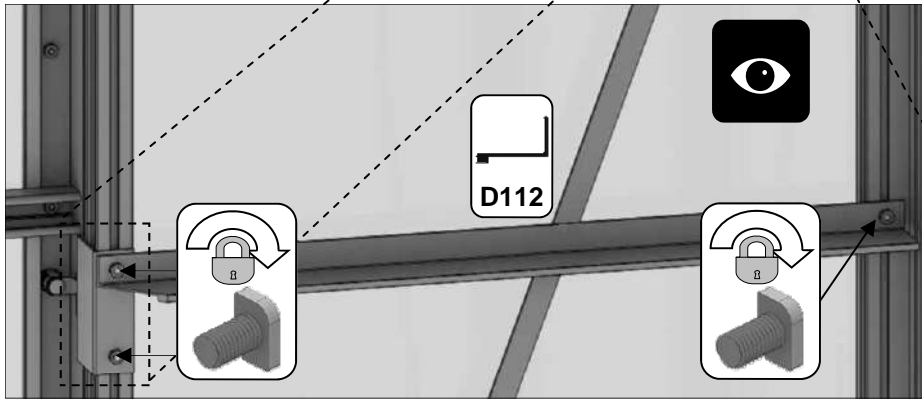
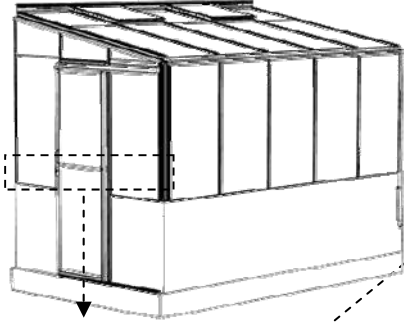
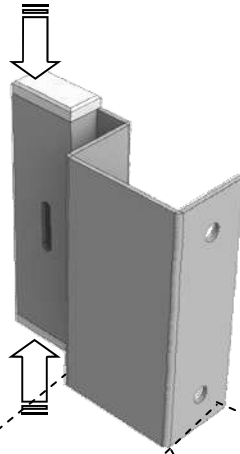

Part No		Quantity
FS6018		1
D312		2
D204L /B		1
D204R /B		1

8

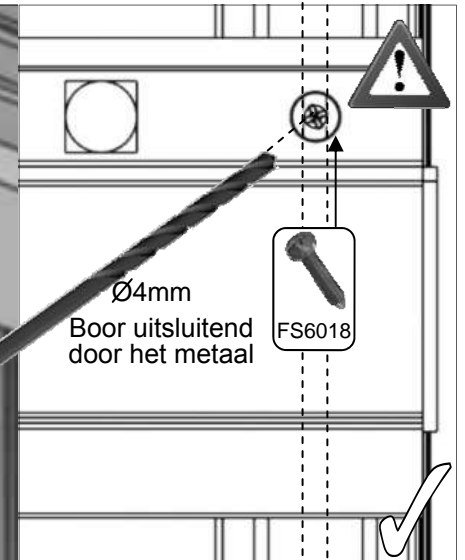
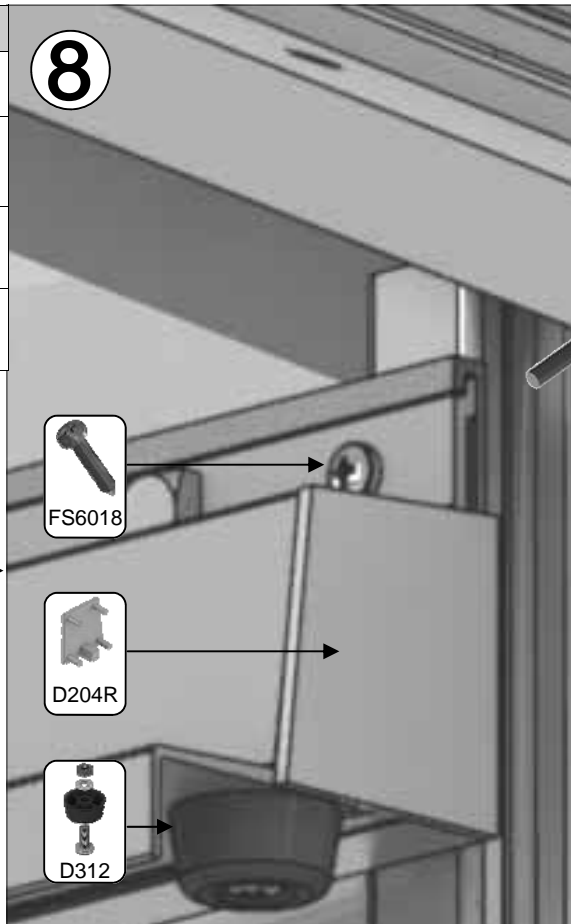
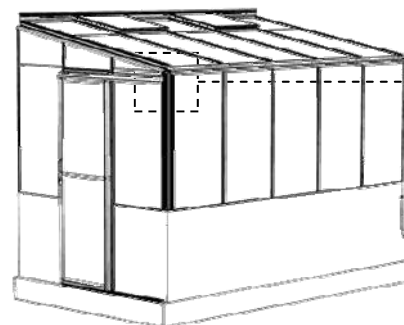

11

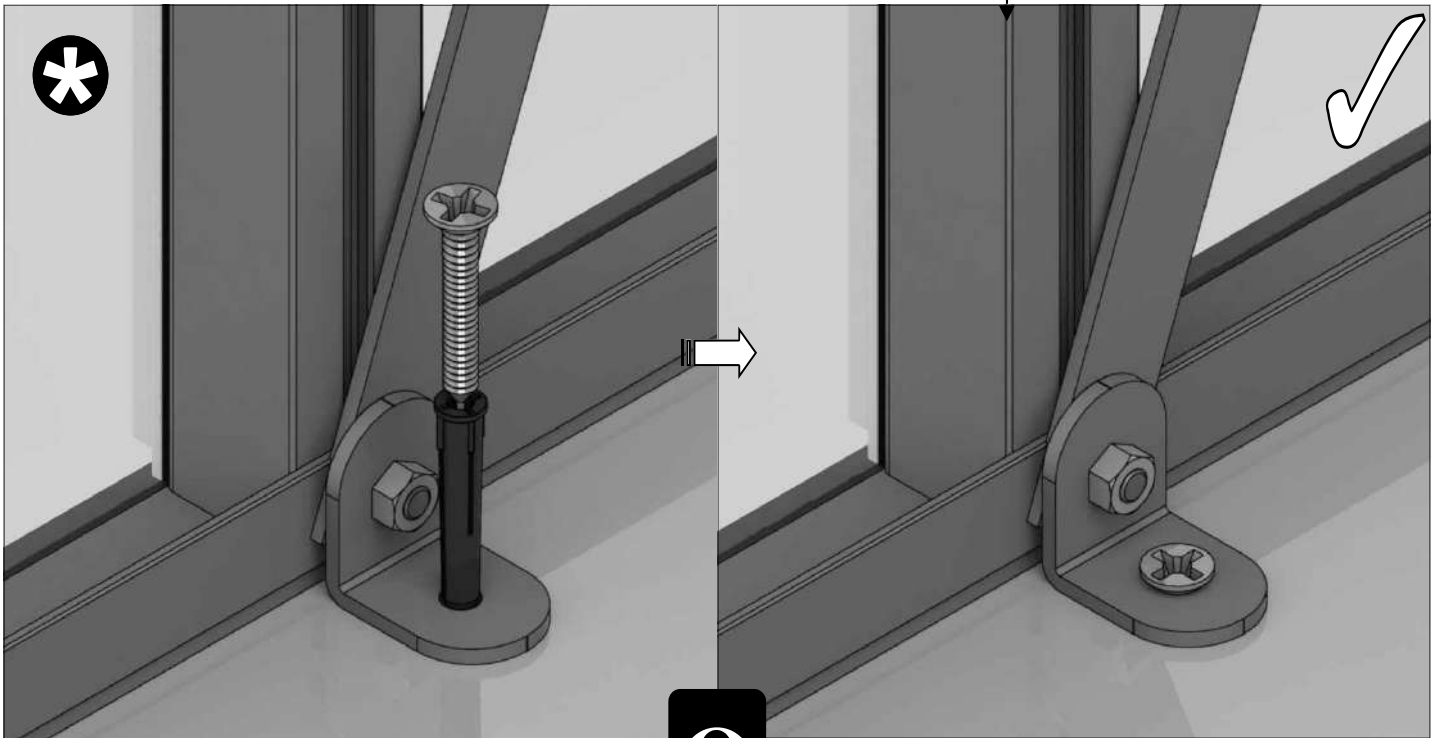
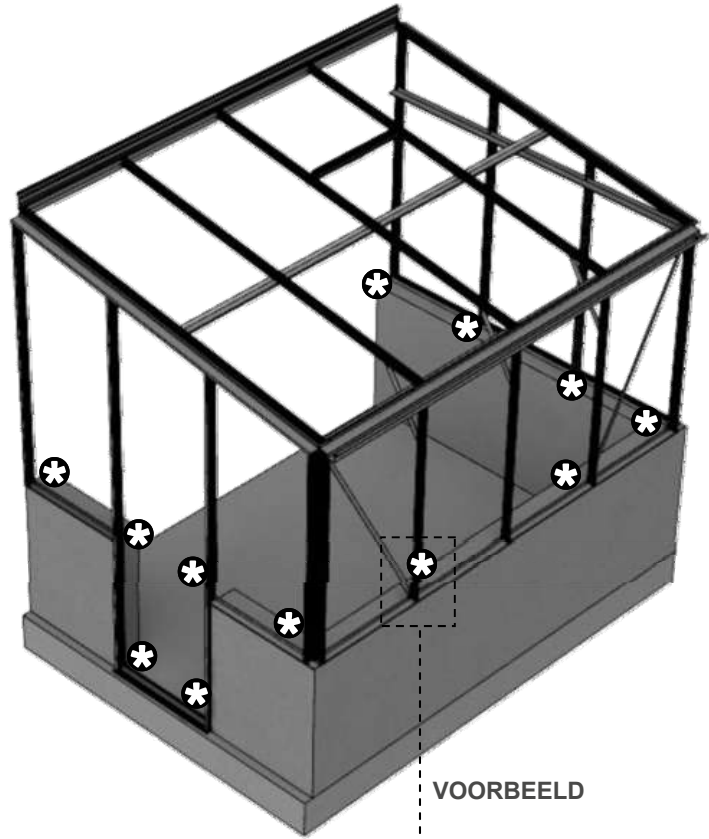
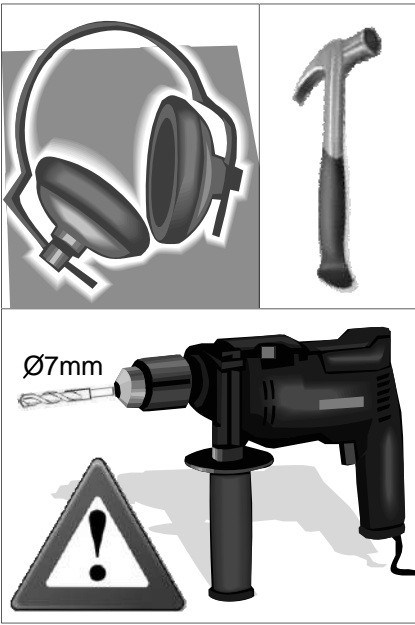

12





Optioneel lamellenraam = {

Part No		mm	Quantity
D168L		552	1
D168R (handle)		552	1
D165		612	2
D166		552	2
FS6013		12	4

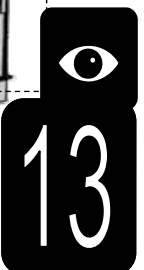
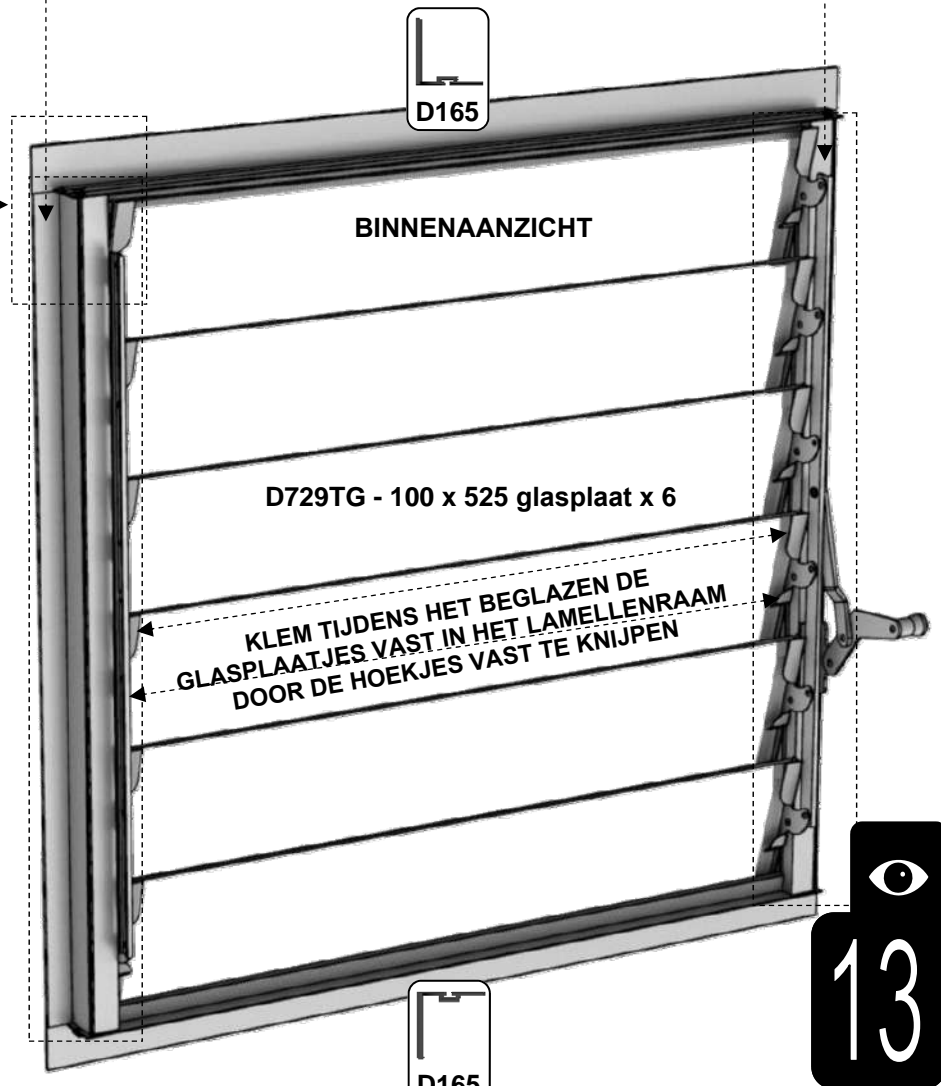
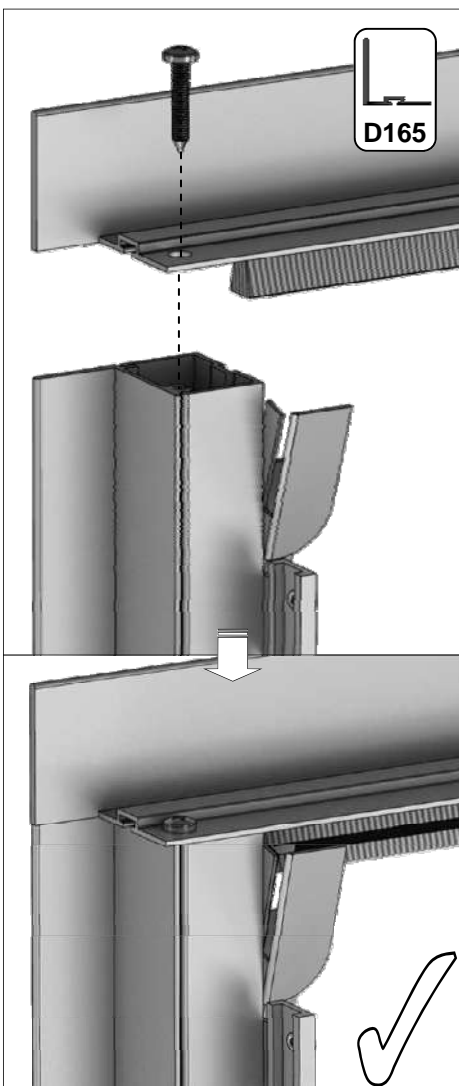
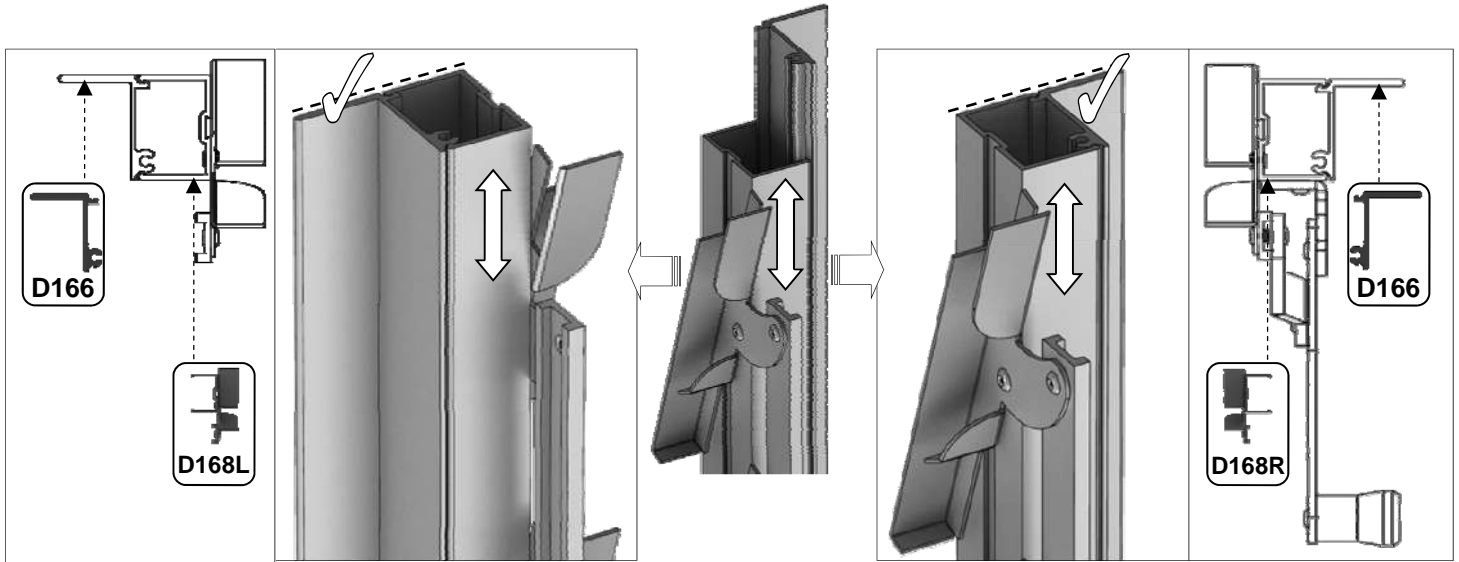



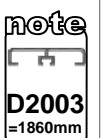
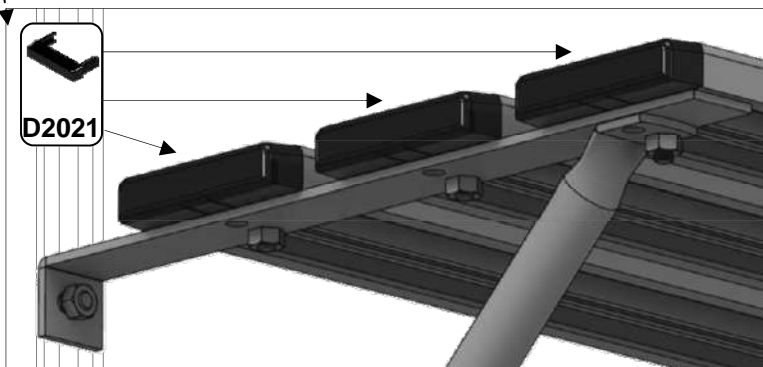
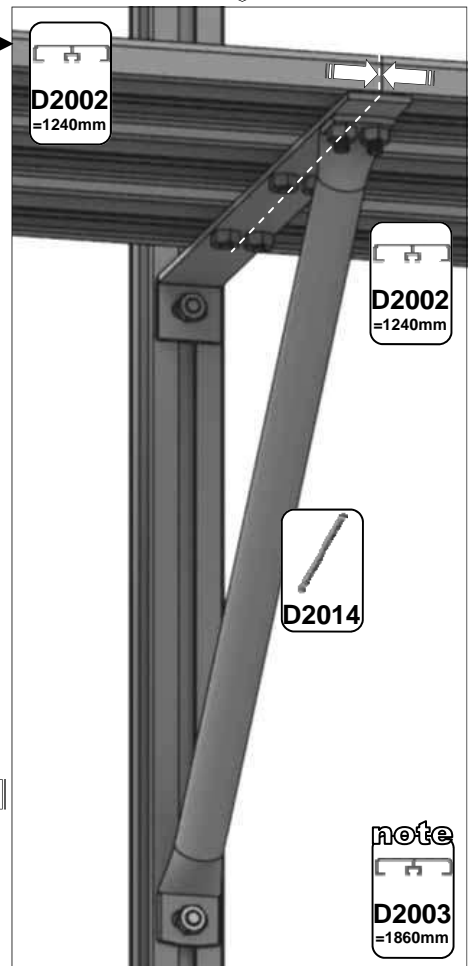
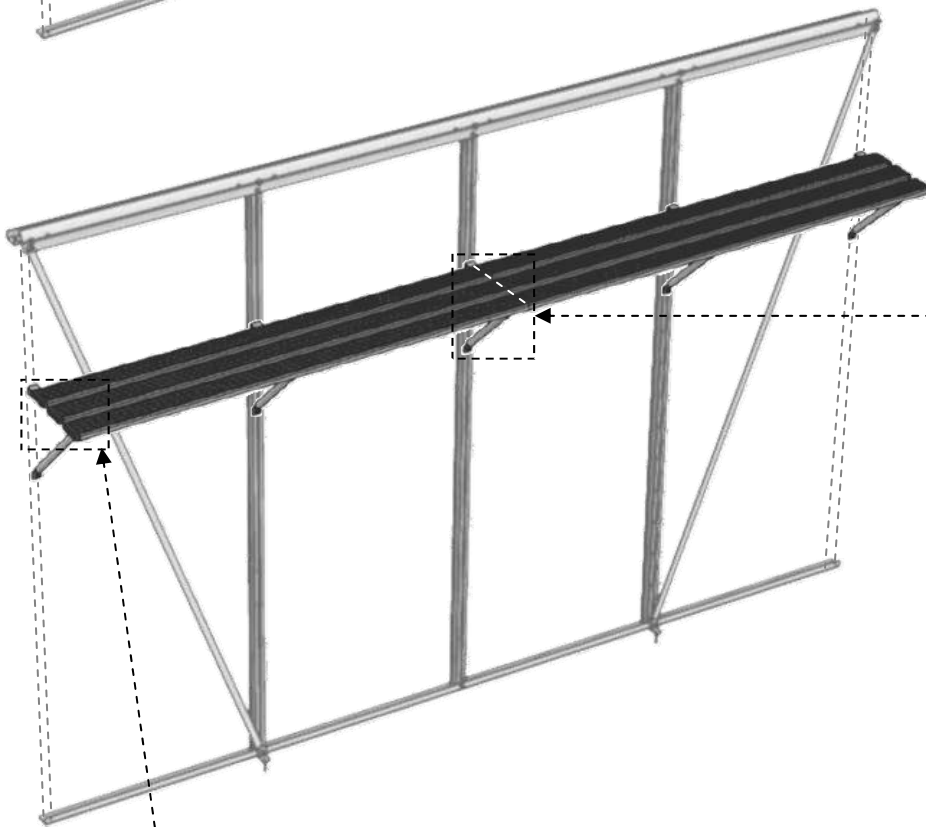
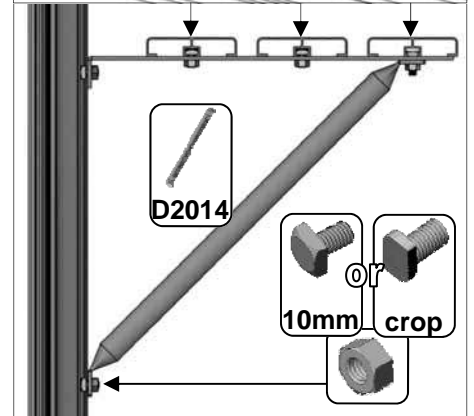
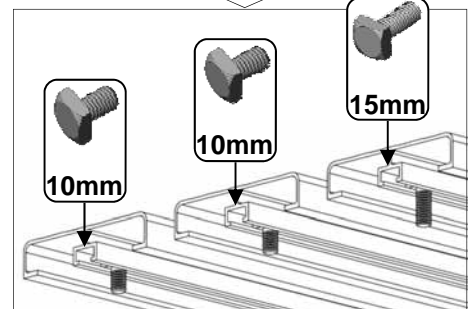
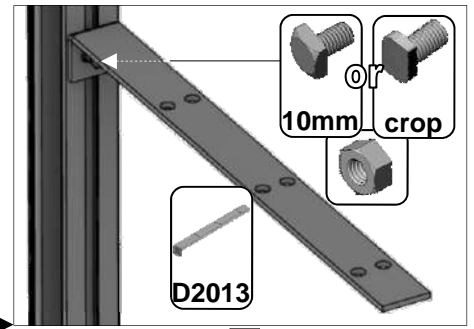
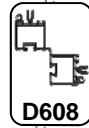
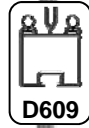
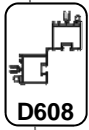
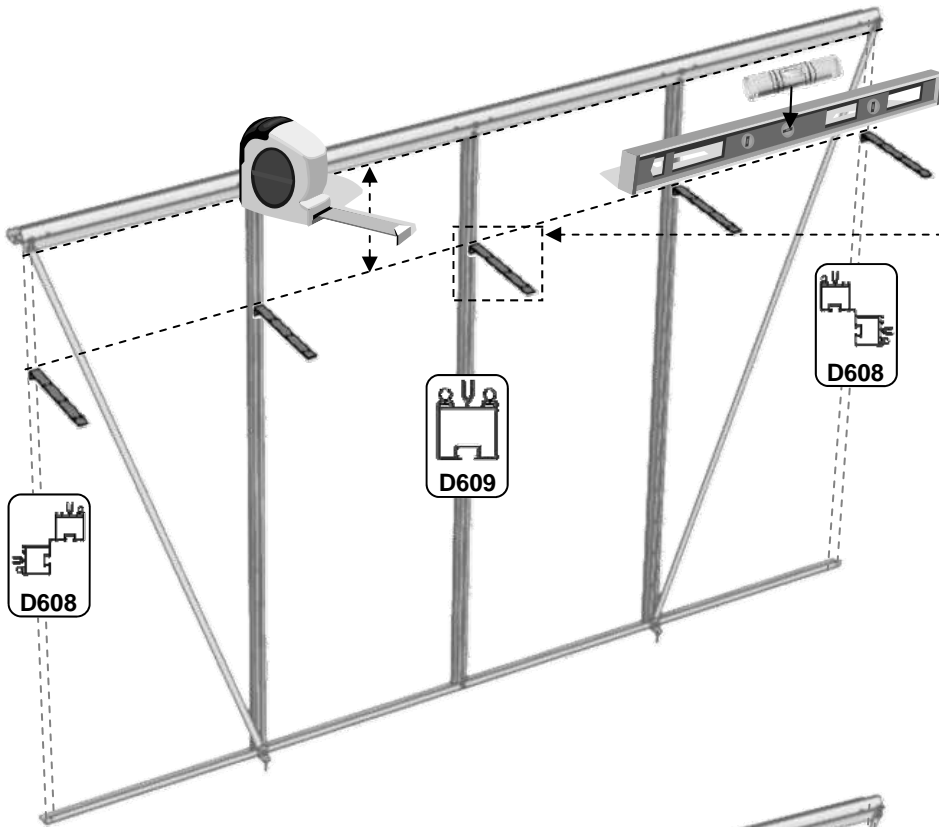

Montage opbergplank (3 latten diep):

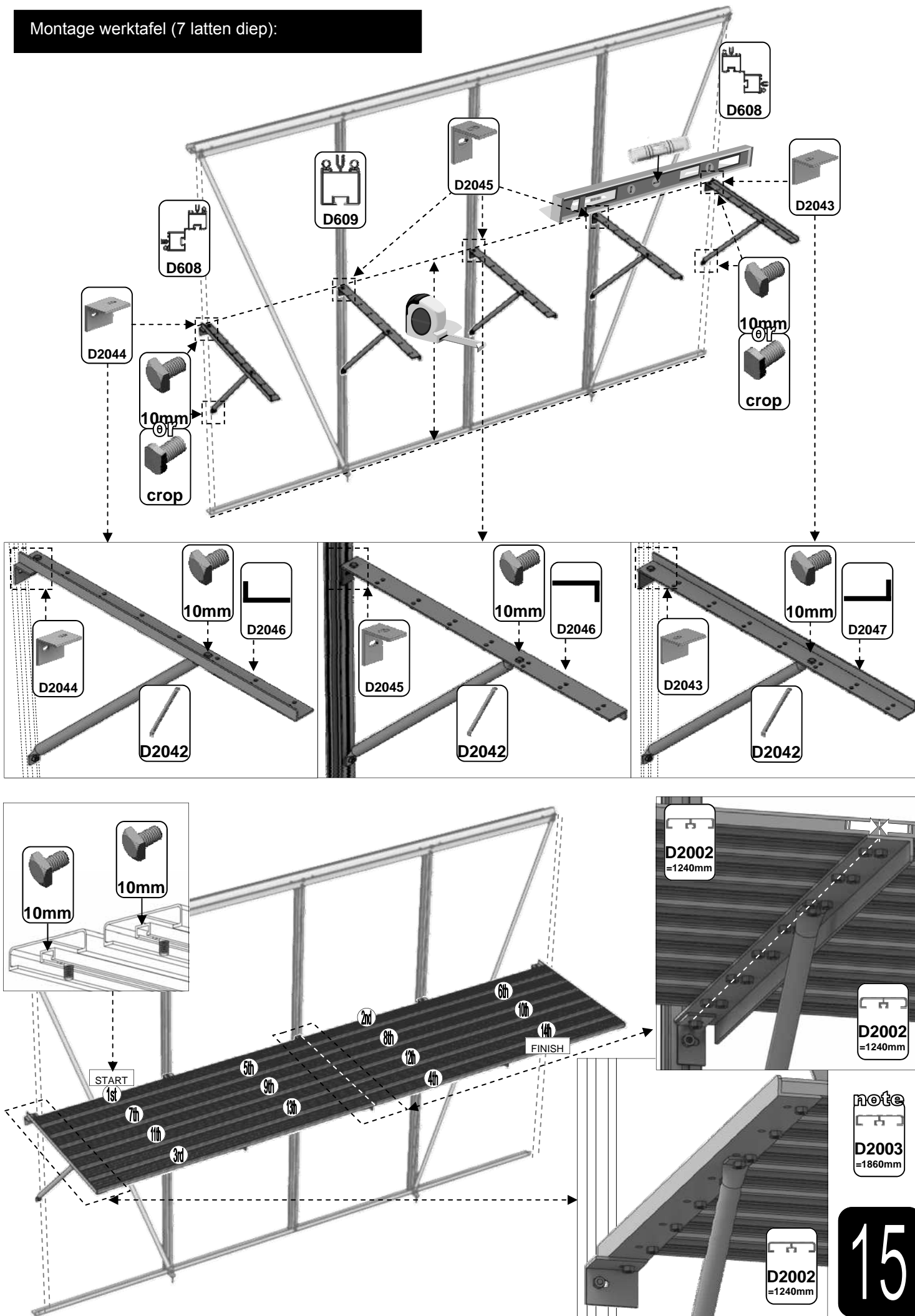

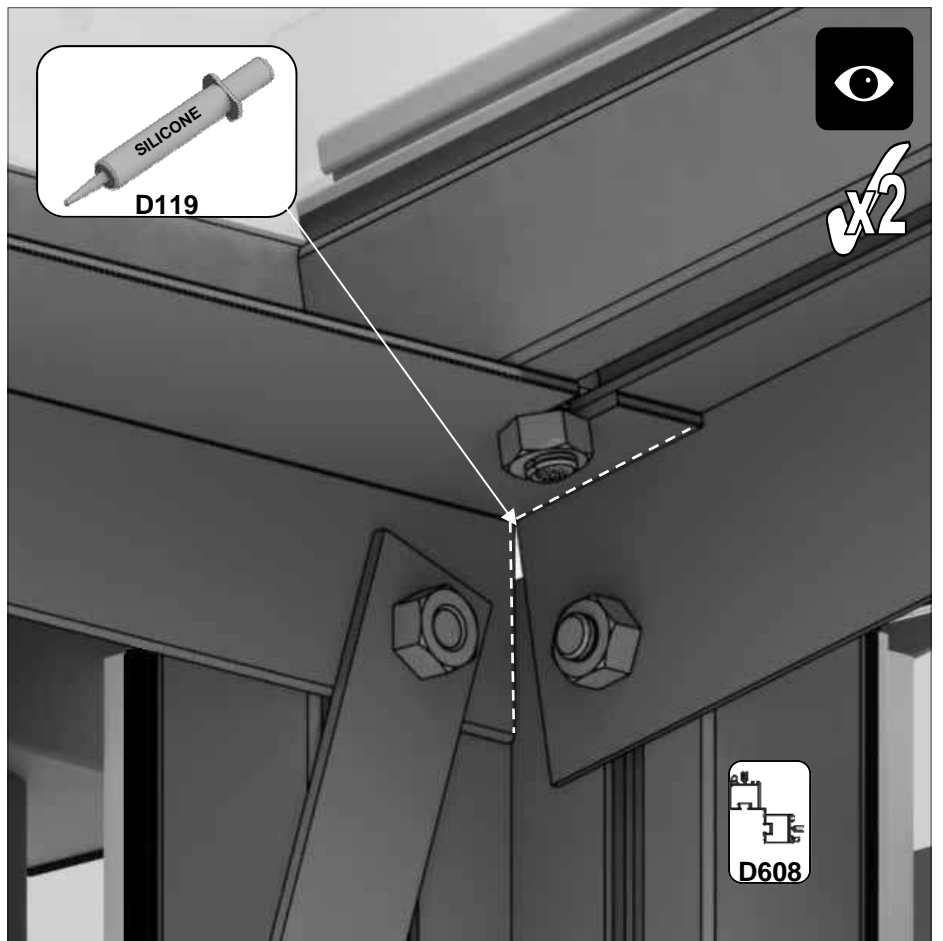
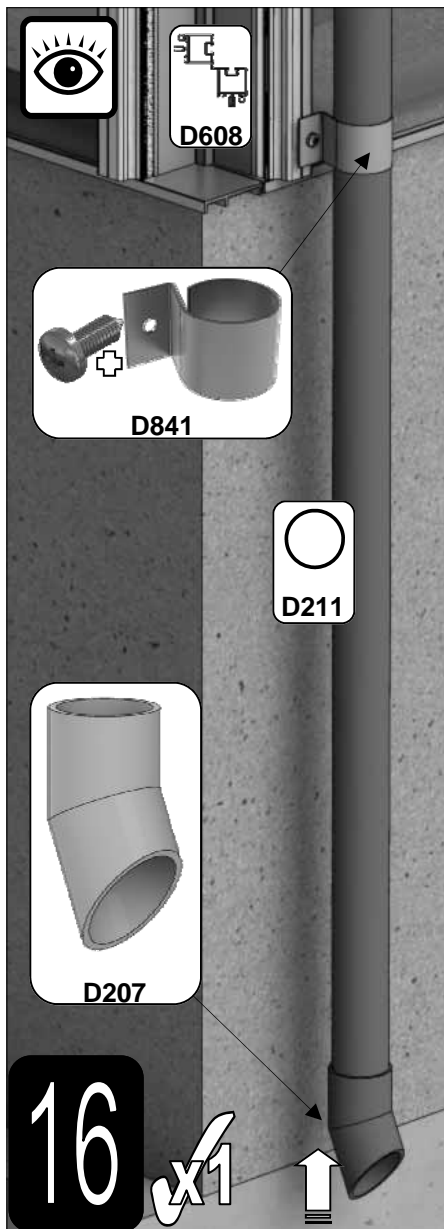
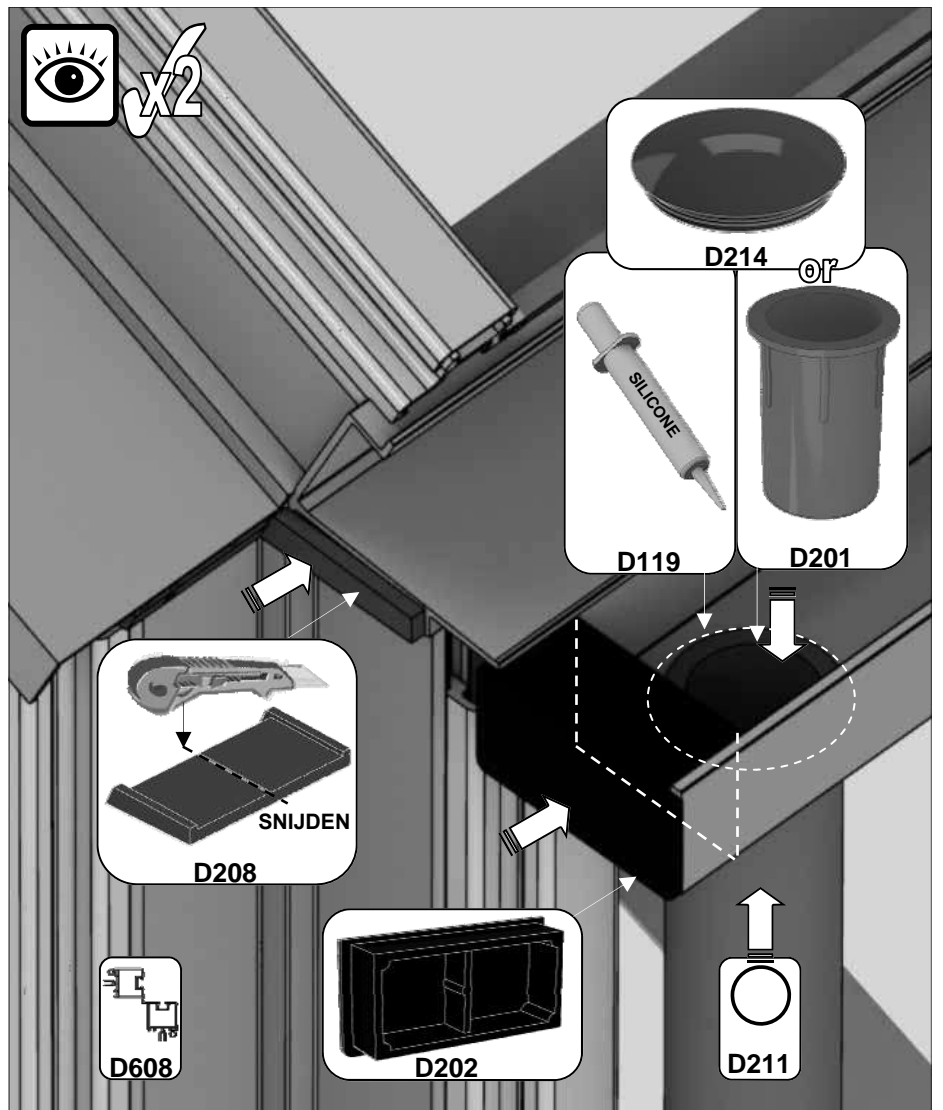
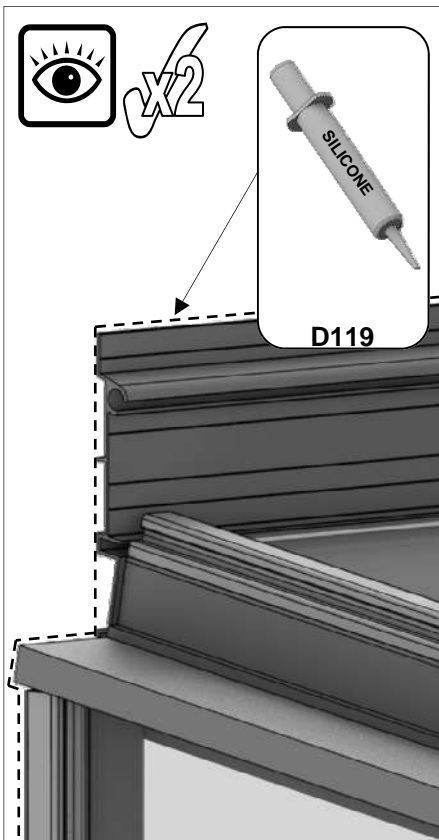



Montage werktafel (7 latten tief):





Part No		mm	Q
D512		1210	1
D086		2510	1
D085		2510	1

Part No		mm	Q
D522		50	1
D163		90	2
D150			1
D845			2
SY-BOLM6X15			13
SYNUTM6			13

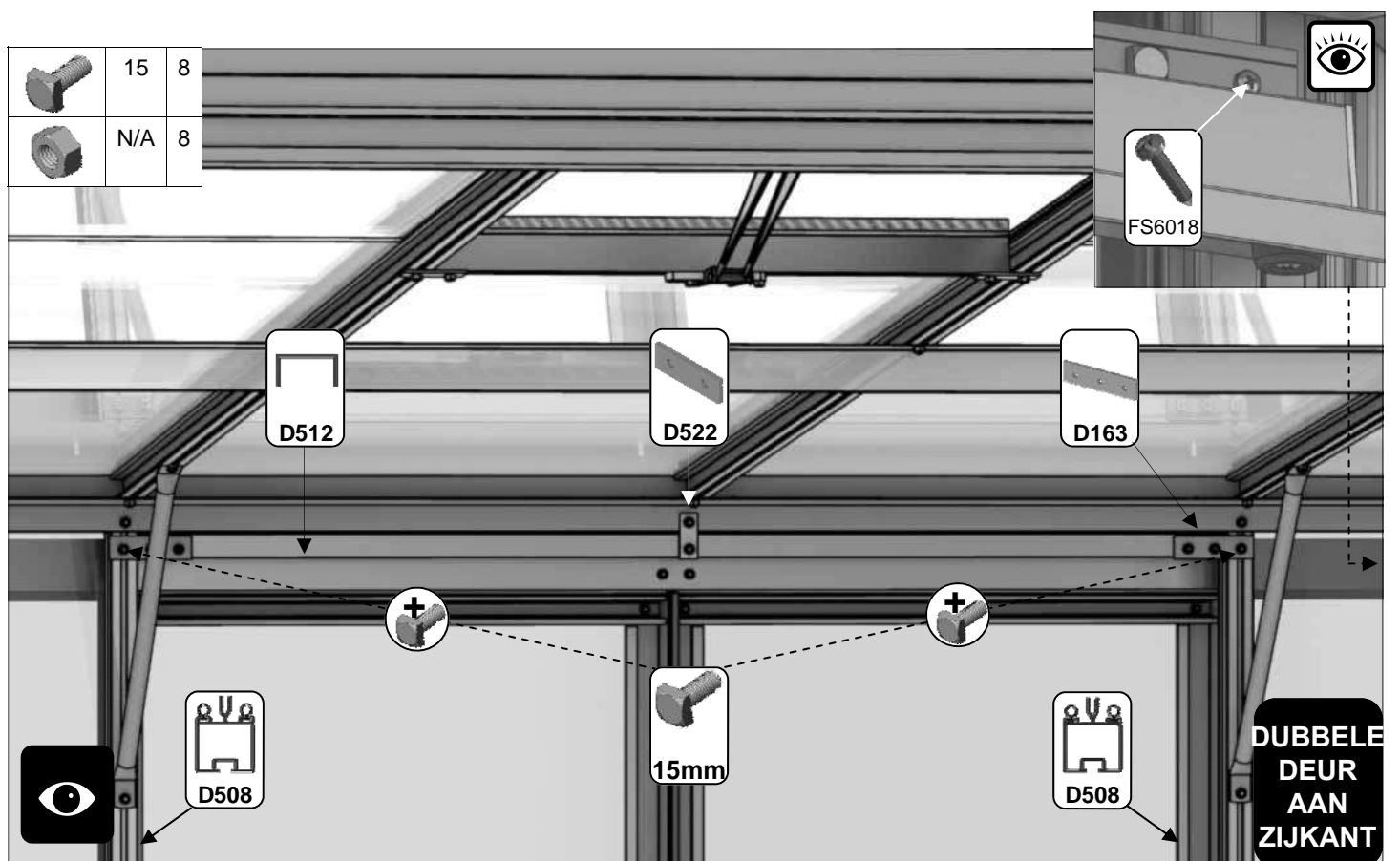
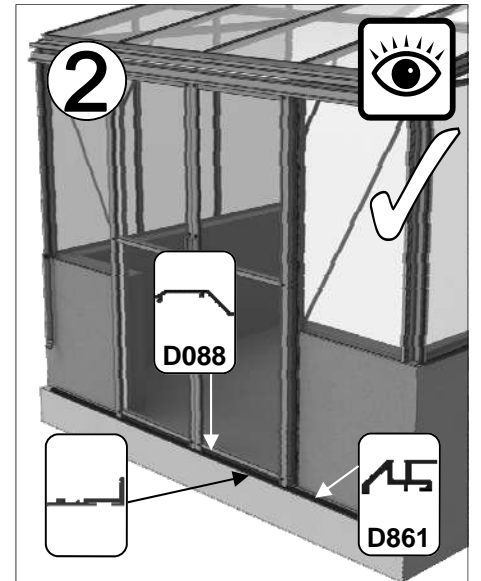
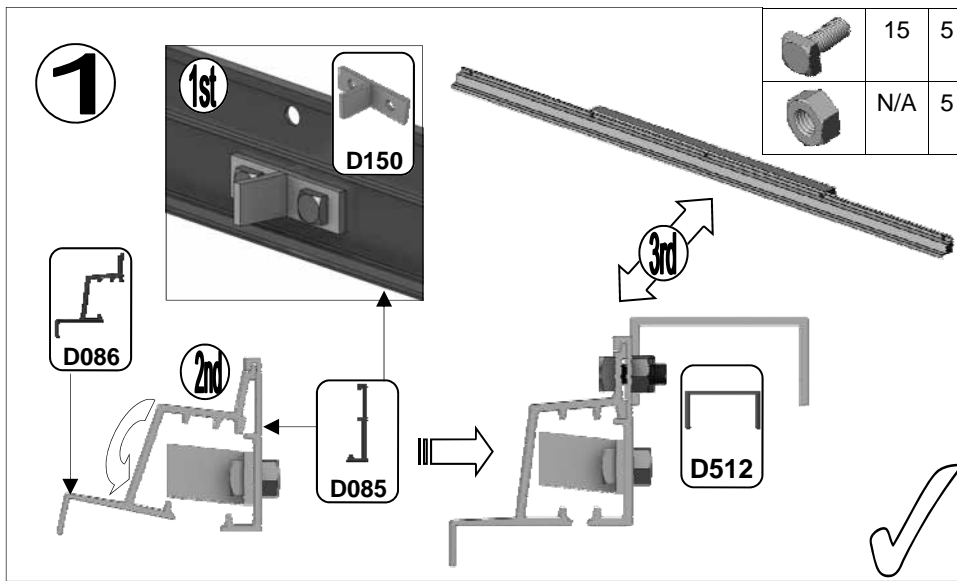
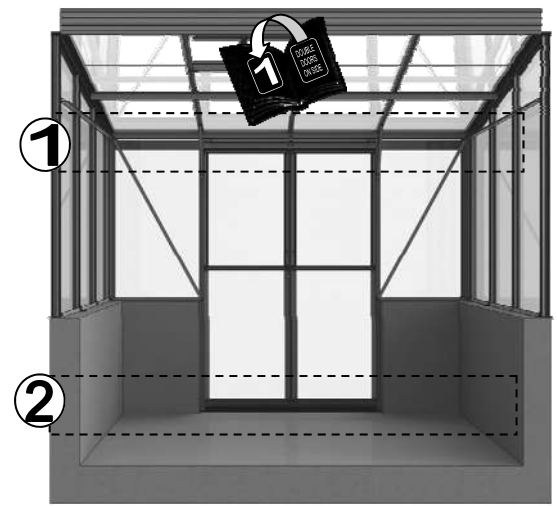

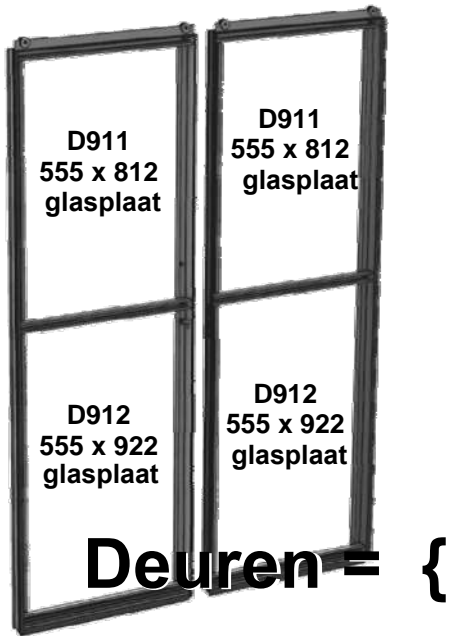

Part No		mm	Q
D094		1824	1
D090 + D347 lock = D301		1824	1
D092 + D156 strike = D303		1824	1
D093		1824	1
D096 + D217 wheel = D307		611	2
D095		611	2
D097		611	2

Part No		mm	Q
D232		905	4
D233		797	4
P053		N/A	2
D225		610	2
D840B		4000	1
D263 PACK x 2		N/A	14
		N/A	14
D261 PACK		N/A	24

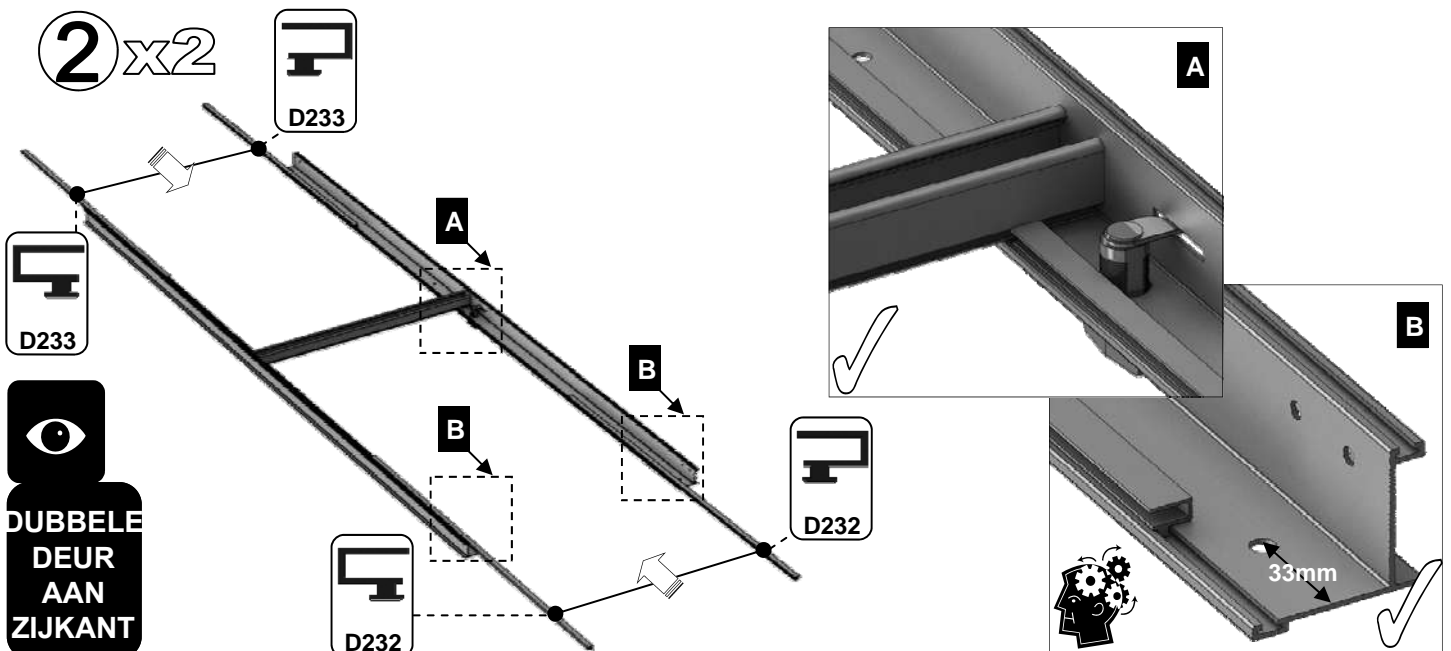
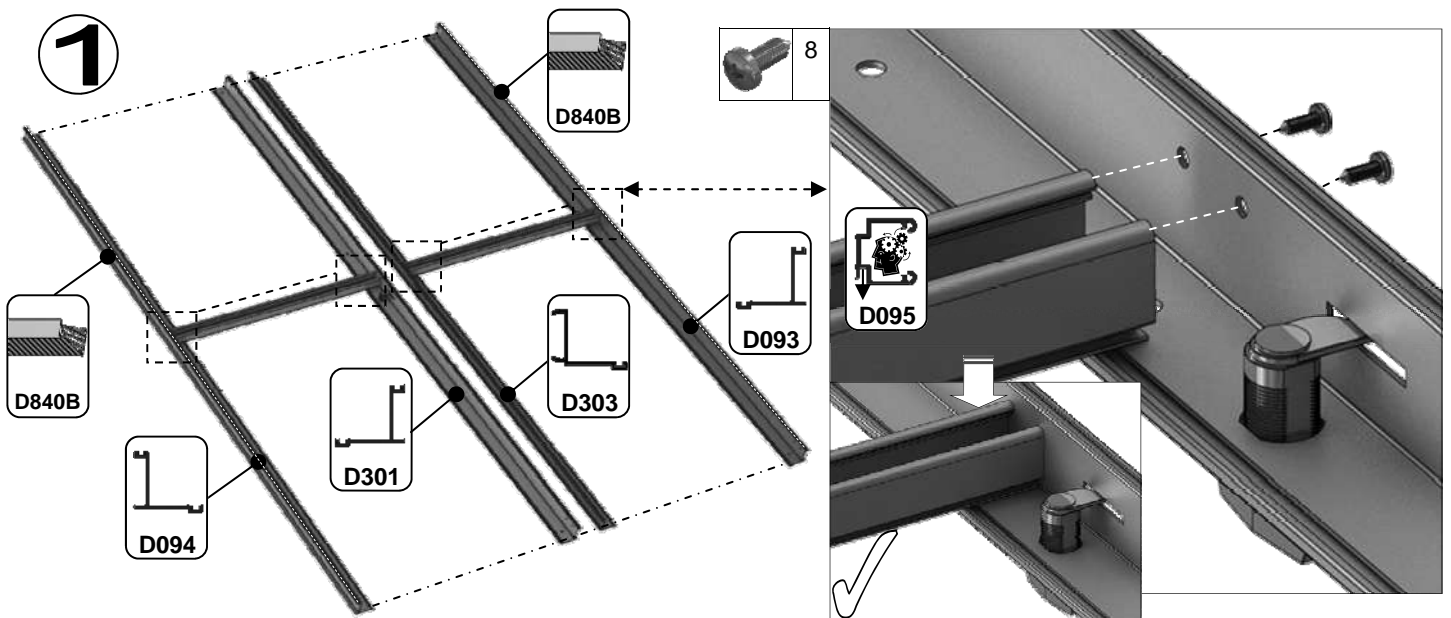

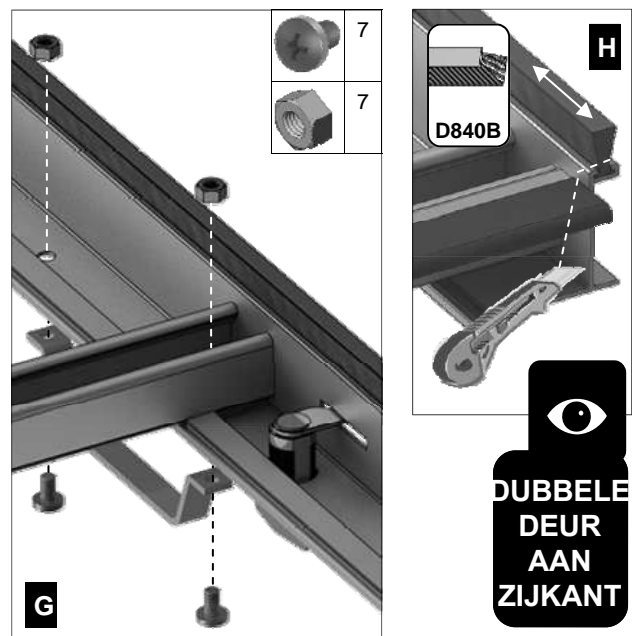
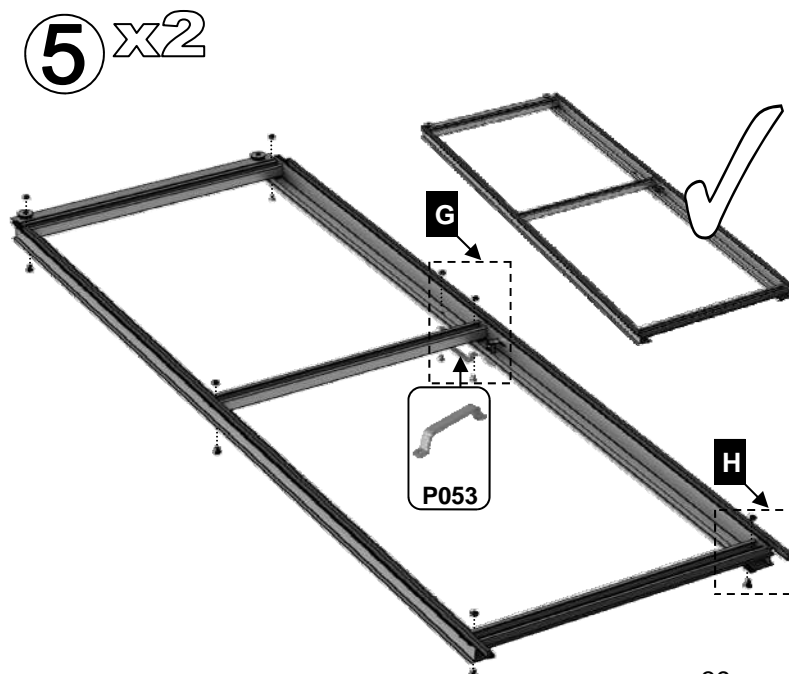
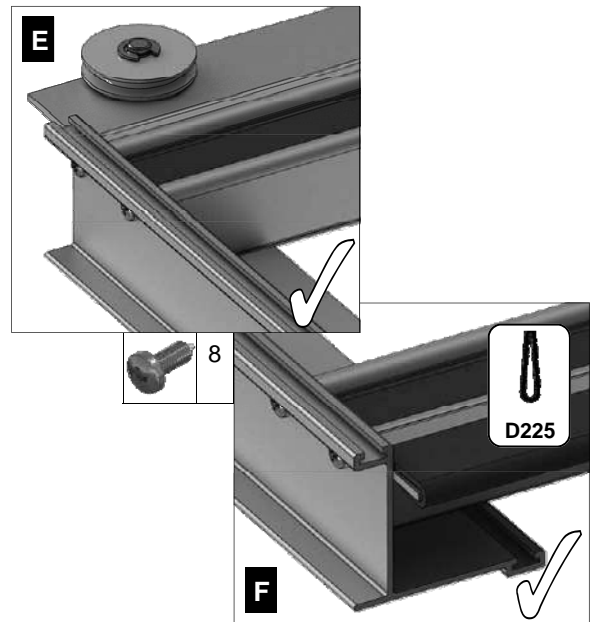
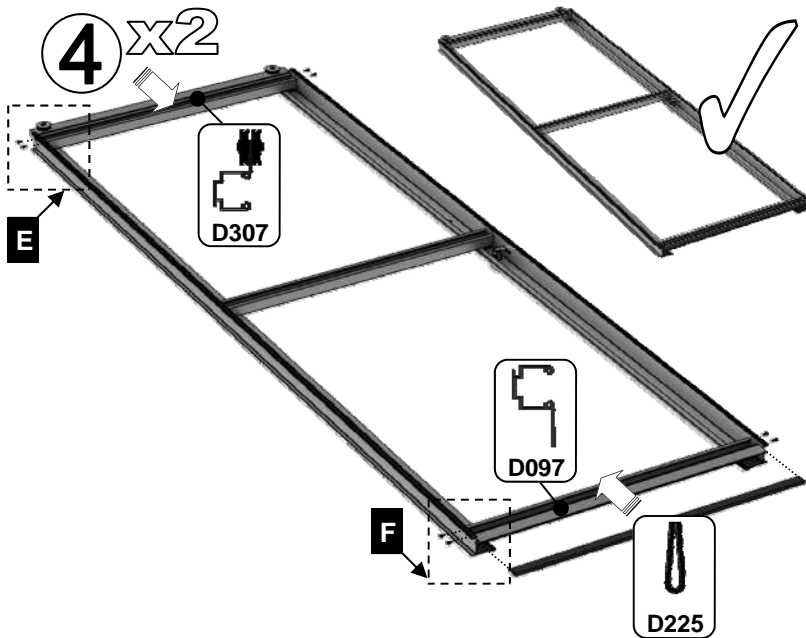
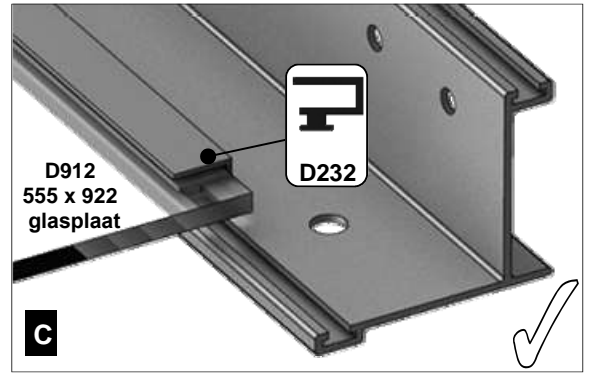
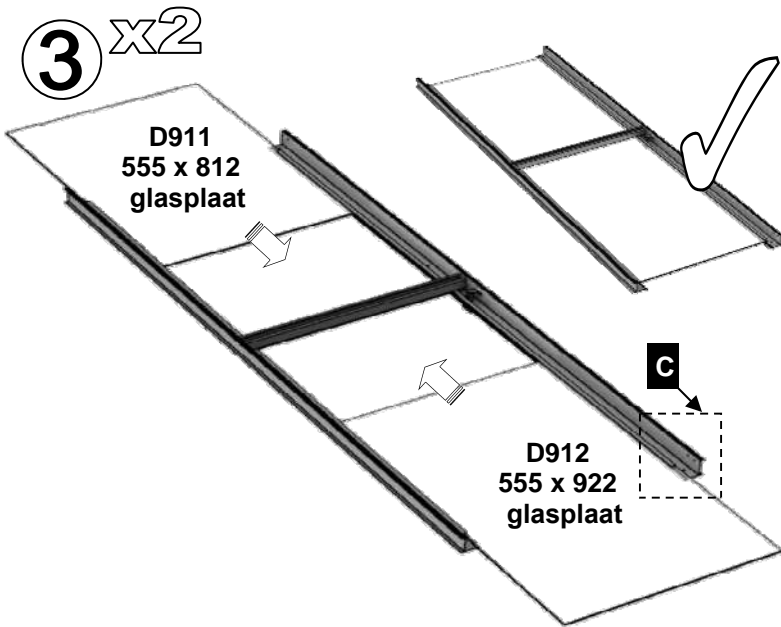

**DUBBELE
DEUR
AAN
ZIJKANT**

Houd er rekening mee dat dit een multinationale handleiding is. Als u fouten ziet of constructief commentaar heeft, stuur dan een e-mail naar sales@robinsonsgreenhouses.co.uk. Dan zullen de nodige wijzigingen worden aangebracht. Hoewel de informatie in dit boekje accuraat is op het moment van publicatie, is het mogelijk dat veranderingen in de loop van het Robinsons beleid van verbetering door ontwikkeling en ontwerp niet worden aangegeven. Wij wijzen op dit feit om overtredingen van de Wet Handelsbeschrijvingen te voorkomen en ook om te informeren dat Robinsons Greenhouses zich het recht voorbehoudt om specificaties en materialen te wijzigen zonder kennisgeving vooraf.



www.robinsonsgreenhouses.co.uk

To contact Robinsons Customer Services email us at sales@robinsonsgreenhouses.co.uk or call us on 01782 385 409.